

# ANTEA AZG 611 78 REV Polar White | 114.0532.312

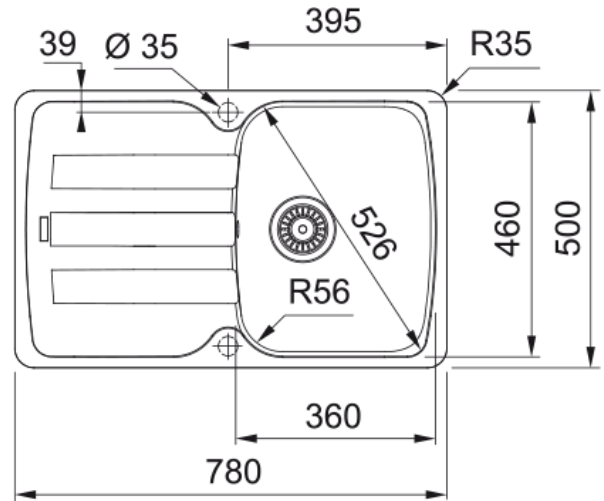

The Franke Antea AZG 611-78 is manufactured from an exceptionally tough material, highly resistant to burns, dents, chips and stains. Pioneered by Franke, it's a unique material with a subtle sheen that is warm to the touch thanks to its close to 80% of quartz sand. The surface is finely textured ensuring high hygiene standards. - Inset installation and reversible with 2 pre-formed tap holes. - 3 1/2" semi-integrated waste with hygienic overflow. - 50 year Guarantee on all Franke sinks.

## Product Information

Sink type	Sink (w/ drainer)
Type of material	Granite
Number of bowls	1
Colour	Polar white
Finish	None

## Dimensions

External size: right to left	780.0
External size: front to back	500.0
Bowl 1 size: right to left	360.0
Bowl 1 size: front to back	460.0
Bowl 1: depth	210.0
Cutout inset: right to left	760.0
Cutout inset: front to back	480.0

## Installation

Minimum cabinet size	45 cm
----------------------	-------

## Product specifications

Installation type	Inset
Waste outlet	3 1/2"
Position of drainer	Reversible drainer

## Product Identification

Product brand	Franke
Product family	Smart
Model range	Antea
Approval logo	Ce
Approval logo	UKCA

## Properties

Drainers number	1
Product reversibility	Yes
Tap ledge	Yes
Waste kit include	Yes
Waste kit type	Manual
Siphon included	No
Number of tap holes	2 - pre-formed
Soap dispenser hole	No