

UBG610-78PW Urban PW Single Bowl | 114.0644.774

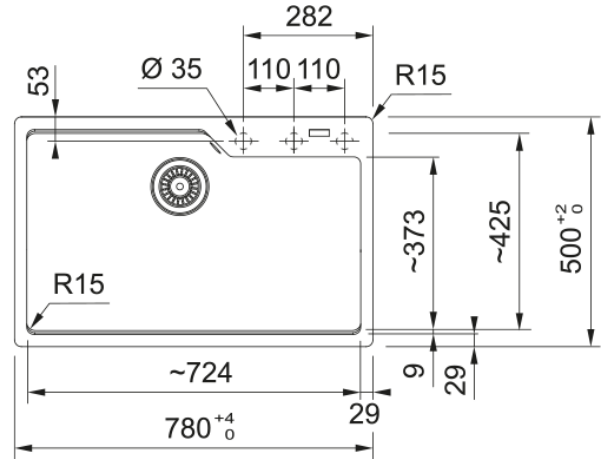

Constructed from 80% quartz sand and 20% durable acrylic resin, a Franke Fraganite sink adds a touch of elegance to any kitchen with its subtle shine. Designed for busy households, this material is highly resistant to temperatures of up to 280° Celsius.

Aspect

Sink type	Bowl (no drainer)
Material type	Granite
Number of bowls	1
Colour	Polar white
Finish	None

Dimensions

Overall length	780.0
Overall depth	500.0
Length	723.0
Depth	425.0
Height	230.0
Cutout inset: right to left	744.0
Cutout inset: front to back	464.0

Installation

Cabinet size	80 cm
--------------	-------

Product features

Installation type	Topmount
Waste outlet	3 1/2"
Position of drainer	No drainer

Product identification

Brand	FRANKE
Product family	Maris
Family	Urban
Approval logo	CE

Properties

Drainer	No drainer
Reversible	No

Tap ledge	Yes
Waste kit	Yes
Waste kit type	Manual
Plumbing kit	No
Tap holes	2 - pre drilled
Soap dispenser hole	Yes - pre drilled