

## UBG620-860N Urban Onyx Double Bowl Sink | 114.0644.586

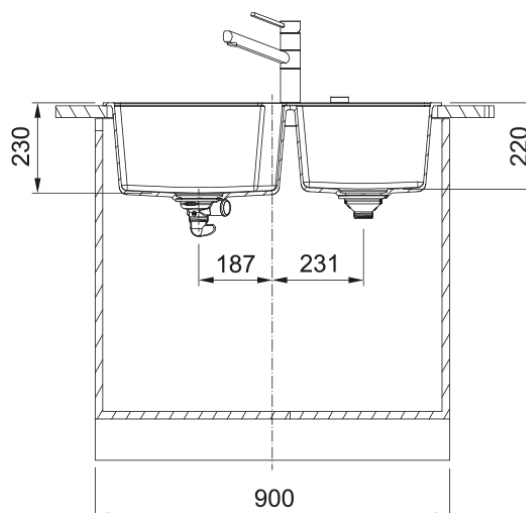

Constructed from 80% quartz sand and 20% durable acrylic resin, a Franke Fraganite sink adds a touch of elegance to any kitchen with its subtle shine. Designed for busy households, this material is highly resistant to temperatures of up to 280° Celsius.

### Aspect

Sink type	Bowl (no drainer)
Material type	Granite
Number of bowls	2
Colour	Onyx
Finish	None

### Dimensions

Overall length	860.0
Overall depth	500.0
Length	432.0
Depth	425.0
Height	230.0
Bowl 2: length	341.0
Bowl 2: Width	364.0
Bowl 2: height	220.0
Cutout inset: right to left	824.0
Cutout inset: front to back	464.0

### Installation

Cabinet size	90 cm
--------------	-------

### Product features

Installation type	Topmount
Waste outlet	3 1/2"
Position of drainer	No drainer

### Product identification

Brand	FRANKE
Product family	Maris
Family	Urban

### Properties

Drainer	No drainer
Reversible	No
Tap ledge	Yes
Waste kit	Yes
Waste kit type	Manual
Plumbing kit	No
Tap holes	3 - pre drilled
Soap dispenser hole	No