

KEPV8AC-STN Chilled fountain anti-vandal | 213.0670.130

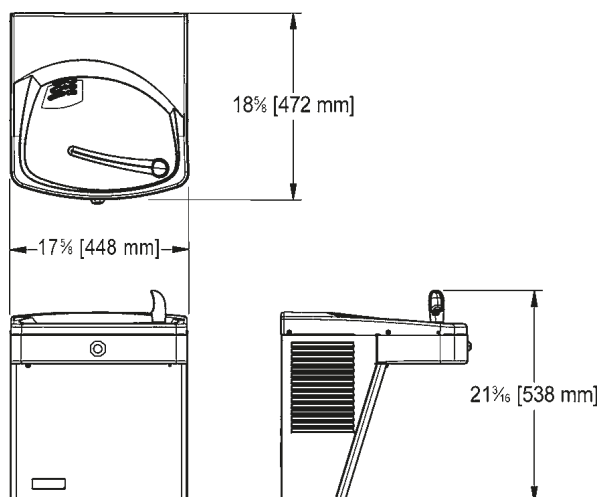

Universal chilled drinking fountain. Waterways are lead-free in materials and construction. Drinking fountains have built-in 100 micron strainers which stop particles before they enter the waterway. Stainless steel top with a one piece, low flow, tamper-proof flexible bubbler. Heavy duty galvanized steel frame. Unit will comply with wheelchair accessibility when properly installed. Compressor is hermetically sealed, reciprocating type, single phase, lifetime lubrication. The condenser is cooled with a permanently lubricated fan motor. Stainless steel cooling tank with continuous copper tubing. Factory preset thermostat. Easily accessible by removal of front panel. R134a refrigerant. Product Certified to NSF/ANSI Standard 61, Annex G (weighted average lead content of 0.25% or less). Models covered by this specification comply with all known Plumbing Codes. Listed by Underwriters' Laboratories to U.S. and Canadian standards. 8 gph chiller, vandal resistant push button, no external stream height adjustment, stainless steel. Optional filter kit F041253-001. 18 5/8 x 17 5/8 x 21 3/16" Overall (FB x LR x H). 472 x 448 x 538 mm Overall (FB x LR x H).

Product Dimensions

Overall front to back	18.583
Overall left to right	17.638
Overall height	21.181

Installation

Wall mounting type	Wall mounting
Recommended wall carrier	IWC2203

Product specifications

Cooling capacity	8 gph
Outlet size	DN32 / 1 1/4"
Inlet size	DN10 / 3/8"
Input supply voltage Hz	60.0
Input supply voltage V	115.0
Motor power	500.0
Wheelchair accessibility	Yes
Certification	NSF
Certification	CSA
Certification	UL

Product identification

Model	KEPV8AC-STN
Brand	FRANKE
Product category	Drinking fountains

Drinking fountain type	Drinking fountains
Features	
Cabinet finish	Brushed stainless
Chilled	Yes
Vandal resistant	Yes
Type of operation	Manual
Drinking bubbler	Yes
Bottle filler included	No