

Saturn Cube Swivel | 115.0562.894

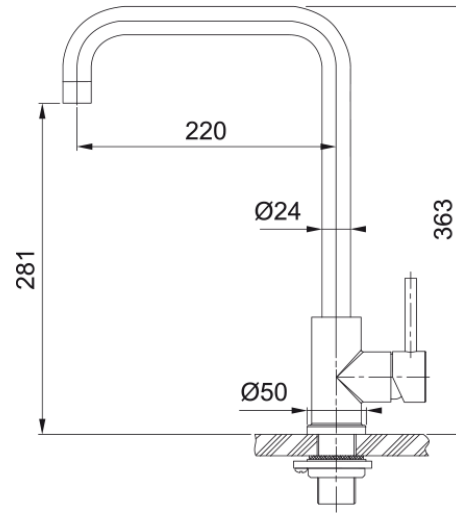

Saturn Cube Swivel, Stainless Steel finish, Overall height 363mm, Side Lever, Ceramic Disk Cartridge with Anti- scold Smart Lime Cleaning Aerator. 15 Year warranty on body construction.

Product Information

Spout version	U - spout
Color	Stainless Steel
Type of material	Stainless steel 304

Dimensions

Height overall	363.0
Tap hole diameter	35 mm
Cartridge dimension	35 mm

Installation

Fixation type	1 bolt
Water supply hose connection	3/8"
Water supply hose length	350 mm

Product specifications

Pressure	High Pressure
Version	Swivel
Tap operation	side lever
Tap rotation	360°

Product identification

Product brand	FRANKE
Product family	Smart
Model range	SATURN

Properties

Eco water saving	no
Type of aerator	Honeycomb