

# Refrigerator FCB 400 V NE E | 118.0629.526

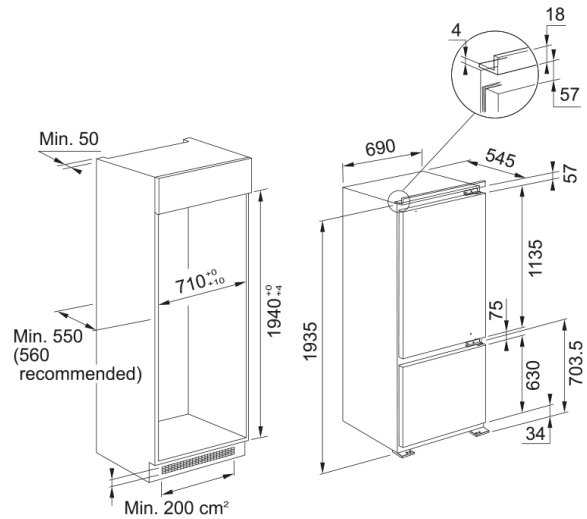

Refrigerator FCB 400 V NE E

## Product Information

Installation type	Built-in
Color	White

## Dimensions

Width: front to back	690.0
Height overall	1935.0
Depth Overall	545.0

## Energy specifications

Voltage	220-240 V
Frequency (Hz)	50

## Product specifications

Type	BI Combi Bottom
Energy efficiency class	E
Bottle balcony	Yes
Bottle rack	Yes
Cold Zone	Yes
Dairy Compartment	No
Door reversibility	Yes
EasyFrost Technology	Yes
Eggs tray	Yes
Freezing capacity KG/24h	12
Number of fridge adj Balconies	4
Number of fridge shelves	2
Ice tray	Yes
Light position	Top/Lateral
No frost system	No
Number of freezing drawers	3
Number of Fresh Zone drawer	1

Packaging Depth	606.0
Packaging Height	2014.0
Packaging Width	732.0
Type of light	LED
Width Cabinet in cm	71
Eggs tray color	Transparent
Functions	Fast cool
Functions	Fast freeze
Functions	Freezer temperature setting
Functions	Fridge temperature setting
Functions	Vacation
Functions	Door open alarm - Fridge only

**Product identification**

Product brand	FRANKE
Product family	Mythos

**Properties**

Defrost	Manual
Capacity net in litre	400
Net capacity freezer in liters	101
Net capacity fridge in liters	299
Fast cooling option	Yes
Fast freezing option	Yes
Noise level (dBA)	35
Climate Class	SN,T