

# UBG 620-43-34 3 1/2" WWK ND WRO PW BOX | 114.0584.892

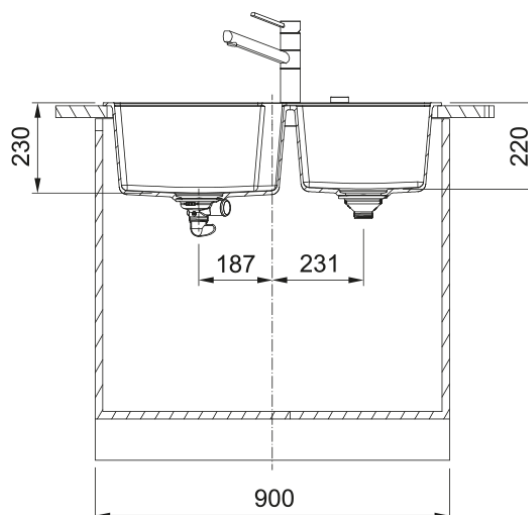

UBG 620-43-34, 3 1/2", 860 mm x 500 mm, with waste kit, without drainer, with hidden rounded overflow, white, drainer basket, carton box, SEA market

## Product Information

Sink type	Bowl (no drainer)
Type of material	Granite
Number of bowls	2
Color	Polar white
Finish	None

## Dimensions

External size: right to left	860.0
External size: front to back	500.0
Bowl 1 size: right to left	432.0
Bowl 1 size: front to back	425.0
Bowl 1: depth	230.0
Bowl 2 size: right to left	341.0
Bowl 2 size: front to back	364.0
Bowl 2: depth	220.0
Cutout inset: right to left	840.0
Cutout inset: front to back	480.0

## Installation

Minimum cabinet size	90 cm
----------------------	-------

## Product specifications

Installation type	Inset
Waste outlet	3 1/2"
Position of drainer	No drainer
Active Twist Compatibility	Yes

## Product identification

Product brand	FRANKE
Product family	None
Model range	Urban

Approval logo	CE
<b>Properties</b>	
Drainers number	No drainer
Product reversibility	no
Tap ledge	Yes
Waste kit included	yes
Waste kit type	manual
Siphon included	yes
Number of tap holes	3 - pre drilled
Soap dispenser hole	no