

UBG 610-50 3 1/2" WWK ND WRO PW DB SEA | 114.0584.295

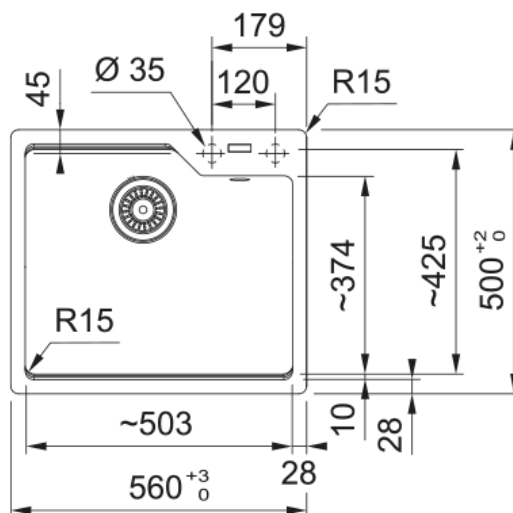

UBG 610-50, 3 1/2", 560 mm x 500 mm, with waste kit, without drainer, with hidden rounded overflow, white,drainer basket,SEA market

Product Information

Sink type	Bowl (no drainer)
Type of material	Granite
Number of bowls	1
Color	Polar white
Finish	None

Dimensions

External size: right to left	560.0
External size: front to back	500.0
Bowl 1 size: right to left	503.0
Bowl 1 size: front to back	425.0
Bowl 1: depth	230.0
Cutout inset: right to left	524.0
Cutout inset: front to back	464.0

Installation

Minimum cabinet size	60 cm
----------------------	-------

Product specifications

Installation type	Inset
Waste outlet	3 1/2"
Position of drainer	No drainer
Active Twist Compatibility	Yes

Product identification

Product brand	FRANKE
Product family	None
Model range	Urban
Approval logo	CE

Properties

Drainers number	No drainer
-----------------	------------

Product reversibility	no
Tap ledge	Yes
Waste kit included	yes
Waste kit type	manual
Siphon included	yes
Number of tap holes	None
Soap dispenser hole	no