

# UBG 620-43-33 3 1/2" WWK ND GSC BOX OA | 114.0695.226

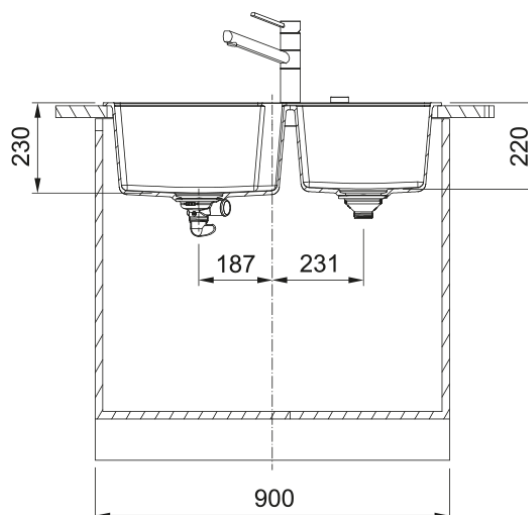

UBG 620-86 WWK ND WRO Oatmeal W Dra B Box with new clip

## Product Information

Sink type	Bowl (no drainer)
Type of material	Granite
Number of bowls	2
Color	Oatmeal
Finish	None

## Dimensions

External size: right to left	860.0
External size: front to back	500.0
Bowl 1 size: right to left	432.0
Bowl 1 size: front to back	425.0
Bowl 1: depth	230.0
Bowl 2 size: right to left	341.0
Bowl 2 size: front to back	364.0
Bowl 2: depth	220.0
Cutout inset: right to left	840.0
Cutout inset: front to back	480.0

## Installation

Minimum cabinet size	90 cm
----------------------	-------

## Product specifications

Installation type	Inset
Waste outlet	3 1/2"
Position of drainer	No drainer
Active Twist Compatibility	Yes
Installation device	Clamp Bag

## Product identification

Product brand	FRANKE
Product family	Maris

Model range	Urban
Approval logo	CE
Approval logo	UKCA
<b>Properties</b>	
Drainers number	No drainer
Product reversibility	No
Tap ledge	Yes
Waste kit included	yes
Waste kit type	manual
Siphon included	yes
Number of tap holes	3 - pre drilled
Soap dispenser hole	no