

FRANKE

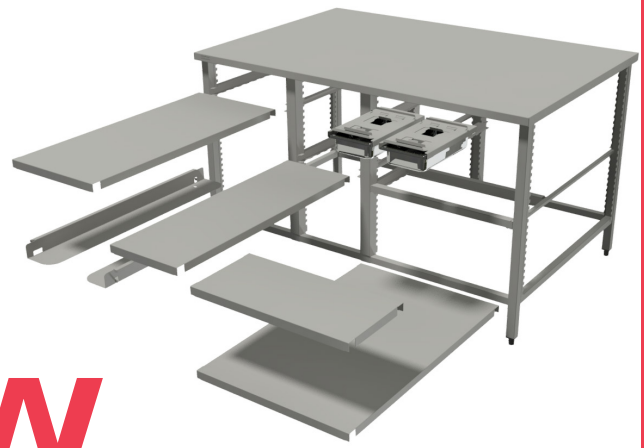

FLEXFLOW SYSTEM

Our fully standardized, modular platform transforms complexity into clarity — providing various sizes and accessories.



Product Features:

- **Modular, Scalable Design**
The system can be initially configured as a basic table and subsequently expanded with shelves, slides, and other accessories. Each module can be easily added, removed or reconfigured. The solution scales in line with business growth, eliminating the need to invest in a completely new system.
- **Flexible System Configuration**
The ability to quickly adapt the system layout and operation to changing production needs - without costly modifications or rebuilds.
- **Standardized Architecture**
The entire system is built according to a consistent design and component standard. All modules follow the same connection system.
- **No Tools Required**
Reconfiguration of the table can be performed without service intervention. All components are tool-free removable.
- **Operational Efficiency**
The system is compact and well-organized, increasing operational efficiency while ensuring efficient storage, better utilization of space, as well as easy cleaning and maintenance. All components are designed without hard-to-clean areas, minimizing the use of fasteners.

- **Flexible Worktop Sizing**

400–1800 mm width,
350–1200 mm depth,
50 mm increments

- **Two heights:**

- 900 mm
- 914 mm

- **Safe Load Shelf Capacity:**

- Maximum load for the complete table setup (including the table's weight): 300 kg
- Maximum load per 1 shelf: 100 kg
- Maximum load per worktop: 125 kg

FRONT VIEW

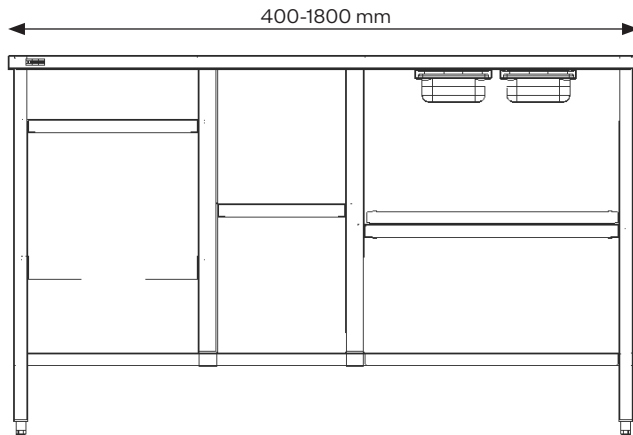

SIDE VIEW

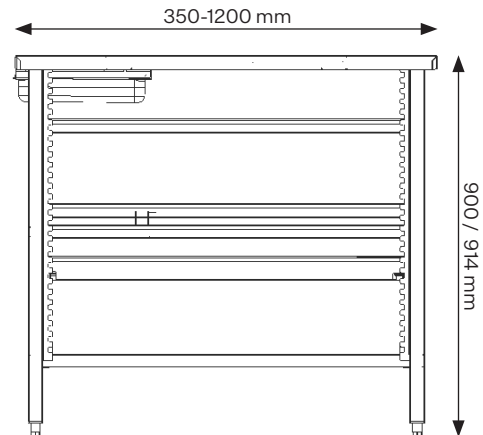

Base Parameters			
Dimensions	min value	max value	increments
Width	400 mm	1800 mm	50 mm
Depth	350 mm	1200 mm	50 mm
Height	900 mm	914 mm	two options

Accessories	Shelf with slides	Basket slides	Pilaster	Middle pilaster	Set cross shelf support	Slide for GN pan
Dimensions	mm	mm	mm	mm	mm	mm
Width	300-1700	125	35	50	300-1700	182
Depth	300-1150	300-1150	23	58	50	322
Height	30	55	675	675	30	22



Would you like to order this product? Contact us today!