

PPX 110-72

- Dimna per foratura top
- Template top cut-out
- Gabarit de decoupe
- Plantilla de corte

- Posizionamento squadrette consigliato
- Recommended fixing clamps position
- Position des pattes de fixation
- Position grapas

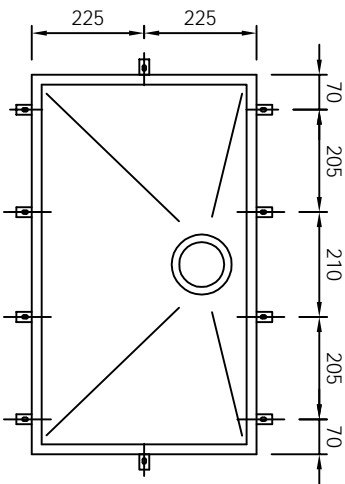

- Dimensioni foratura top
- Cut-out sizes
- Dimensions de la decoupe
- Dimensiones de corte

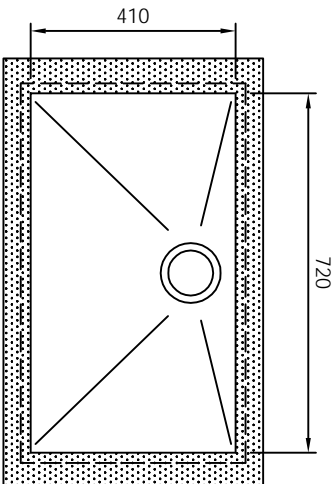

COD. 0271763
 BARCODE EAN 13
 76 12319 48108 6

- Base mm 900
- Cabinet mm 900
- Casson mm 900
- Mueble mm 900

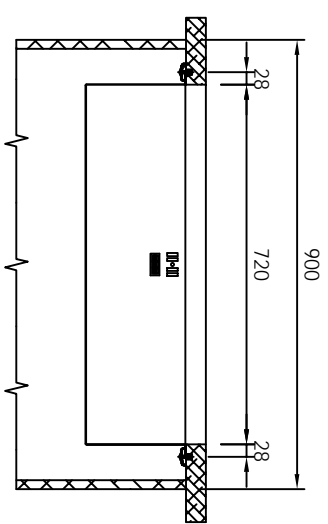

- Schema di fissaggio
- Fixing details
- Schema de fixation
- Detalle de fijation

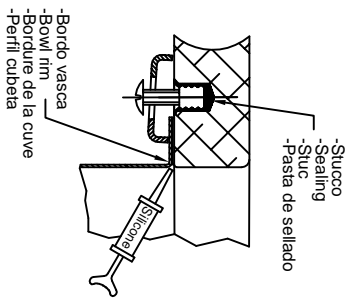
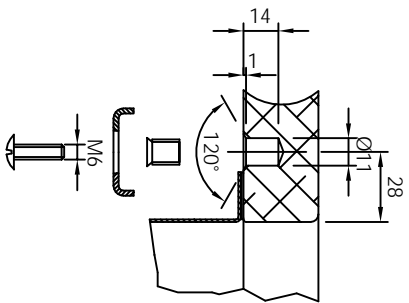

- Si raccomanda sigillatura con silicone
- Silicone recommended
- Assure l'etanchete au silicone
- Sillicona

720

410