

- Dima per foratura top
- Template top cut-out
- Gabarit de decoupe
- Plantilla de corte

- Posizionamento squadrette consigliato
- Recommended fixing clamps position
- Position des pattes de fixation
- Position graspas

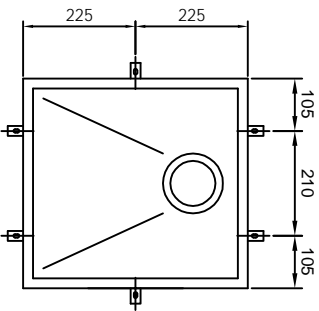

## PPX 110-38

- Base mm 600
- Cabinet mm 600
- Caisson mm 600
- Mueble mm 600

- Dimensioni foratura top
- Cut-out sizes
- Dimensions de la decoupe
- Dimensiones de corte

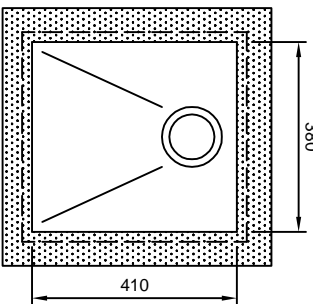

- Schema di fissaggio
- Fixing details
- Schema de fixation
- Detalle de fijation

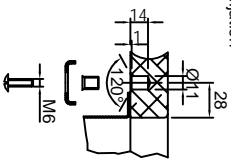
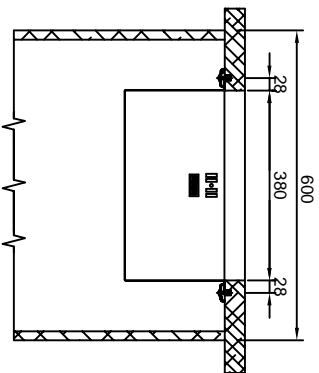

- Stucco
- Sealing past
- Stuc
- Pasta de sellado
- Bordo vasca
- Bouil rim
- Bordure de laque
- Perfil cubeta



COD. 0271761  
BARCODE EAN 13  
76 12319 48107 9

- Si raccomanda sigillatura con silicone
- Silicone recommanded
- Assure l'etancheitee au silicone
- Silicona