

SINK MIXERS

Product Range 2012

KITCHEN
SYSTEMS

FRANKE

INTRODUCING FRANKE'S NEW RANGE OF SINK MIXERS

(Enix Square, Highrise & Projectline)

Elegant Design & Excellent Quality

Franke Kitchen Systems have introduced a new range of Sink Mixers. Each sink mixer has been carefully designed with the end user in mind, ensuring that they receive the highest quality components, with excellent back-up support - the trusted Franke Brand.



SMART LIME CLEANING AERATOR:*

- Smart Lime Resistance - maximising the life-span of the aerator
- No need to disassemble the aerator for cleaning - simply rub the lime away using your finger
- Perfect stream quality even under difficult low conditions
- Very low noise level
- High quality, the Smart Lime Cleaning Aerator cannot be crushed
- Integrated anti-clogging dome screen - filters sediments and particles

*Excluding Enix Square



MIXER ACCESSORIES

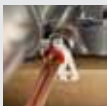

TAP BRACE

Product Code:
303020



TAP HOLE CUTTER

Product Code:
301355



TAP HOLE STOPPER

Product Code:
303043

GUARANTEE

Franke Sink Mixers carry a 5 year guarantee on the body construction against manufacturing defects, with a 2 year guarantee on the cartridge.

All guarantee's are subject to proper installation and proof of purchase is required for all enquiries.

For all enquiries contact the Call Centre on 086 1 372 653

CARTRIDGE:

“Sedal” is the leading European manufacturer of Sink Mixer Cartridges in over 11 Countries.

Features:

- Noise suppressor of 17-18 decibels
- Anti-scold set for standard operation can be reset. (Refer to registered plumber).
- Endurance test of 70,000 cycles, complies with EN 8 14 International Standards
- Reduced low rate for green rating
- Suitable for balanced water pressure of 200 - 600kPa



BRAIDED CONNECTORS:

- Stainless Steel braiding
- Cross-linked inner hose
- Brass nuts - ½ inch / 15mm



NEW



ENIX SQUARE

Features:

- Ceramic Disk Cartridge with Anti-scald
- Solid DZR Brass Construction
- Chrome Plated
- 5 Year guarantee on body construction
- 2 Year guarantee on ceramic cartridge



Enix Square Swivel
Product Code: 305050

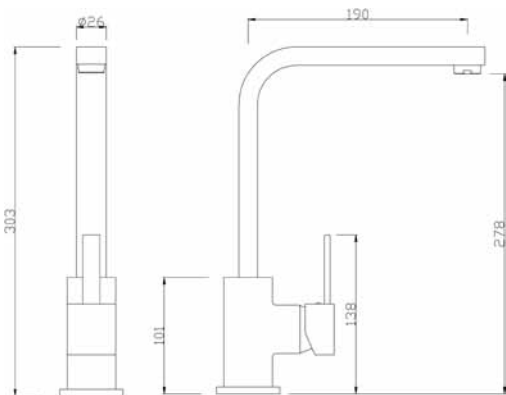

NEW



HIGHRISE

Features:

- Ceramic Disk Cartridge with Anti-scold
- Solid DZR Brass Construction
- Smart Lime Cleaning Aerator
- Chrome Plated
- 5 Year guarantee on body construction
- 2 Year guarantee on ceramic cartridge



High Rise Swivel

Product Code: 305060

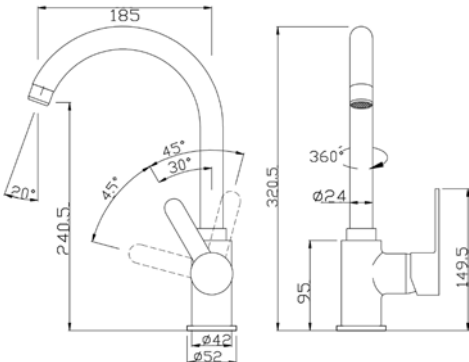

NEW



TURCHESO

Features:

- Ceramic Disk Cartridge
- Solid Brass Construction
- Chrome Plated
- 5 Year guarantee on body construction
- 2 Year guarantee on ceramic cartridge



Turcheso Swivel
Product Code: 305055

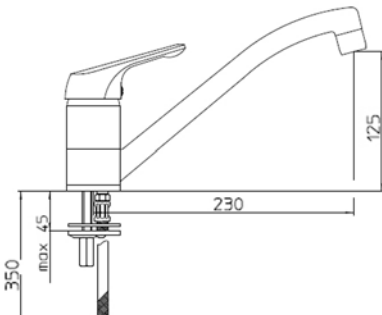

NEW



PROJECTLINE

Features:

- Ceramic Disk Cartridge with Anti-scold
- Solid DZR Brass Construction
- Smart Lime Cleaning Aerator
- Chrome Plated
- 5 Year guarantee on body construction
- 2 Year guarantee on ceramic cartridge



Projectline Single Lever
Product Code: 305065

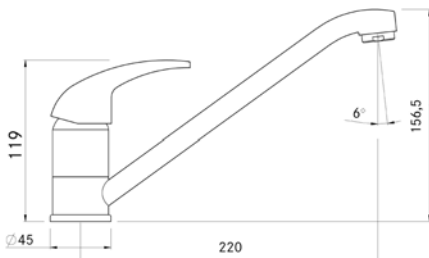



DESIGNER

Features:

- Ceramic Disk Cartridge
- Solid Brass Construction
- Chrome Plated
- 5 Year guarantee on body construction
- 2 Year guarantee on ceramic cartridge

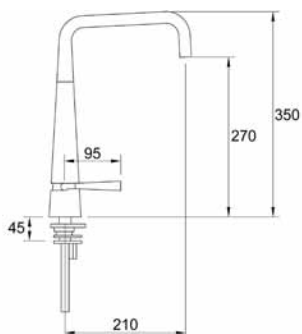

Designer Swivel **Product Code: 303224**



SD80 SOAP DISPENSER

Features:

- Manufacture from chromium plated brass
- Incorporates a replaceable 1 Litre polyethylene container for use with liquid soap
- 5 Year Warranty on Body

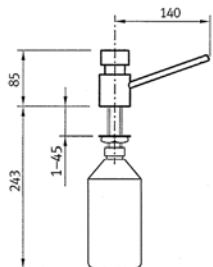
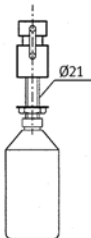

SD80 Soap Dispenser
Product Code: 359802



BILLY

Features:

- Ceramic Disk Cartridge
- Solid Brass Construction
- Chrome Plated
- 5 Year guarantee on body construction
- 2 Year guarantee on ceramic cartridge



Billy Joystick Professional
Product Code: 303220

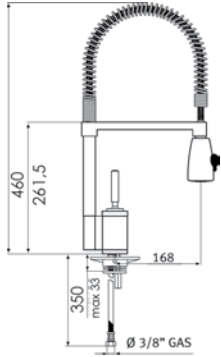

Billy Joystick Swivel
Product Code: 303219

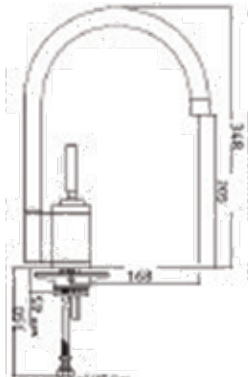



ZODIACO

Features:

- Ceramic Disk Cartridge
- Solid Brass Construction
- Chrome Plated
- 5 Year guarantee on body construction
- 2 Year guarantee on ceramic cartridge



Zodiaco Chrome - Swivel
Product Code: 303218

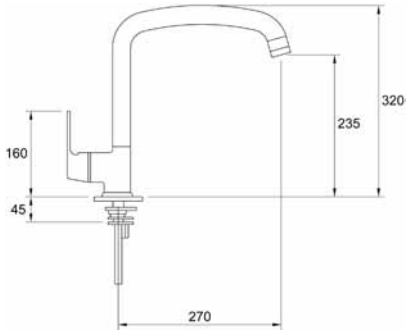

Zodiaco Chrome - Retractable
Product Code: 303217

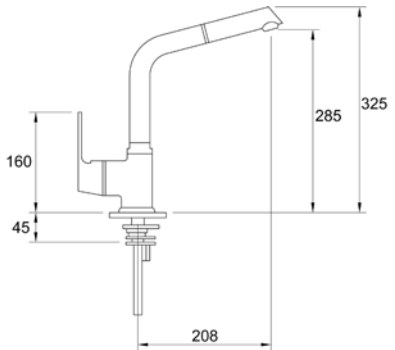



FABELLA II

Features:

- Ceramic Disk Cartridge
- Solid Brass Construction
- Chrome Plated
- 5 Year guarantee on body construction
- 2 Year guarantee on ceramic cartridge



Fabella II - Retractable
Product Code: 303356

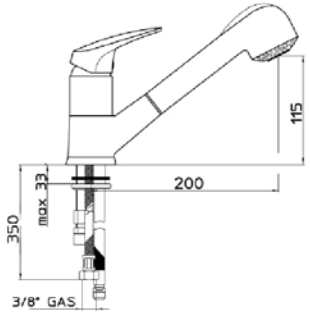

Fabella II - Prep Bowl
Product Code: 303354

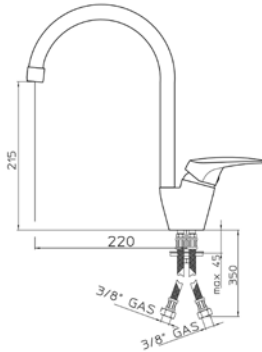



CASCADE

Features:

- Ceramic Disk Cartridge
- Solid Brass Construction
- Chrome Plated
- 5 Year guarantee on body construction
- 2 Year guarantee on ceramic cartridge



Cascade Prep Bowl
Product Code: 303232

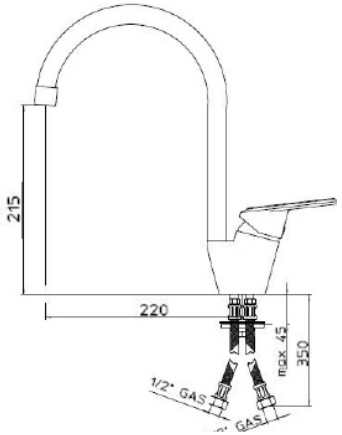

Cascade Swivel **Product Code: 303355**

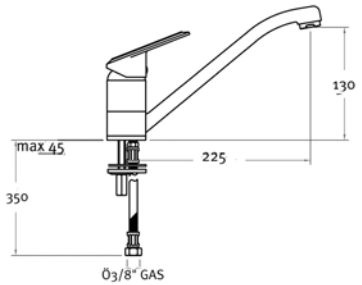



KUBUS FILTERFLOW WATER PURIFICATION

Discover the unique advantages and health benefits of the Franke Kubus Filterflow water filtration system. Designed and manufactured by British engineers, and fitted with a premium-grade carbon activated cartridge, the Franke Kubus Filterflow is a health-conscious and quality drinking water filtration system.

Features:

- Water Purification Filter
- Dispenses Hot, Cold and Filtered Water
- Carbon Activated Cartridge
- Solid Brass Construction
- Chrome Plated
- Removes Chlorine, Lead, Harmful Bacteria, Parasites and Cysts including Cryptosporidium
- Improves Taste, Odour and Colour
- Kubus Filterflow retains Beneficial Minerals such as Calcium and Magnesium - essential for a healthy diet
- Guaranteed for 5 Years on Body Construction



Kubus Swivel
Product Code: 303236

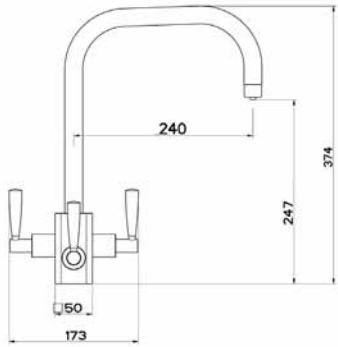

KUBUS FILTERFLOW INSTALLATION

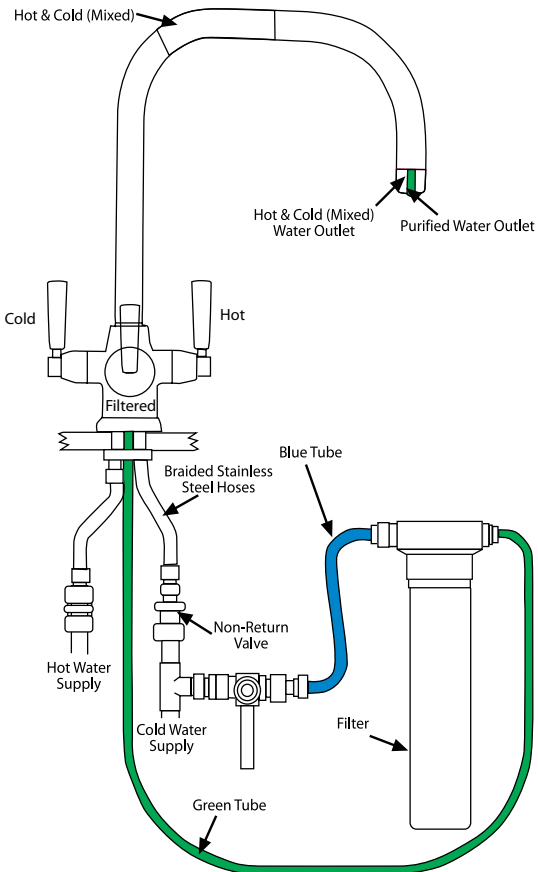

FRANKE KITCHEN SYSTEMS (PTY) LTD

CALL CENTRE

Tel: 086 1 372 653
Fax: (+27-31) 450 6303
e-mail: callcenter.fsa@franke.com
Website: www.franke.co.za

DURBAN

1194 South Coast Road,
Mobeni, Durban, 4092.
South Africa.
Tel: (+27-31) 450 6300
Fax: (+27-31) 450 6303
e-mail: enquiry.fsa@franke.com

GAUTENG

77 Roan Crescent,
Sage Corporate Park North,
Old Johannesburg Road,
Midrand, 1682
South Africa

CAPE TOWN

Unit 29, Gold Street,
Northgate Business Park, Northgate Estate,
Cape Town, 7405
South Africa

www.franke.co.za

DISCLAIMER

The information and data supplied in this brochure is based on information believed to be reliable, however it is not binding and inaccuracies may occur. Franke reserves the right to change specifications and design at any time without notice.

© 2010 by Franke Kitchen Systems (Pty) Ltd. All rights reserved under the Copyright Act of 1987 with amendments. Reproduction of any of the content, full or partial, is allowed only with the prior written approval of Franke Kitchen Systems (Pty) Ltd. No reasonable requests will be refused provided conditions as laid out are met.