

2 DESIGN LINES - 1000 POSSIBILITIES

Expanded product range for washroom accessories

1.5

mm of stainless steel encases the STRATOS fixtures line and 0.8 mm the RODAN line. Material number 1.4301 (AISI 304) is used in accordance with DIN EN 10088. The formula 18/10 stands for 18% chromium and 10% nickel. This composition gives the material its particular characteristics.

HIGH-QUALITY MATERIAL

The use of stainless steel as the material of first choice for products in public and semi-public washrooms has become today's standard for good reasons. This material is robust and, easy to maintain, and therefore is very durable which makes the products economical over the life time of the building. Sanitary fixtures that inhibit vandalism and are easy to clean help building operators to keep service and maintenance costs to a minimum.

Stainless steel is not only resistant to moisture and most acids, it also stands out due to its hardness, durability, high tolerance of heat and cold, and hygienic characteristics. Dirt and oil can easily be washed from the smooth, pore-free surface. Scratches and gouges on faceplates lose their sharp edges quickly and blend in to the surface.

"Stainless steels contain at least 10.5% chromium (Cr) and no more than 1.2% carbon (C). They form a self-regenerating surface layer (passive layer) that gives the material its resistance to corrosion, thereby ensuring significantly improved characteristics compared to unalloyed steels. Franke uses steels with a higher chromium content and nickel as an additional alloy component for its sanitary fixtures. This combination further increases resistance to corrosion."

Source: Yasar Renkci, dipl. engineer metallurgy TU, Franke





HYGIENIC MATERIAL

Practical experience shows that using high-quality materials reduces the staining of products that helps to maintain the appearance of heavily used washrooms. Wash stations and accessories take on a hygienic atmosphere. Thanks to its durable and hygienic characteristics, stainless steel provides clean and, safe products for public washrooms.



Appropriate care products:

Brushes with natural or synthetic bristles, textiles made of chemical or natural fibres, microfibre cloths, non-woven plastic textiles, natural leather, sponge cloths, sponges, high-pressure cleaners, steam cleaners, etc. Toothpaste, household cleaners, window cleaners and natural cleaning agents such as vinegar water (20/80) are well suited for removing heavier stains.

The following cleaning agents and cloths can be purchased from Franke. Ask your specialist dealer.

Designation:	Item number:
Twister: Container incl. sponge	7612210034558
Multiclean: Cleaner	7612210031885
INOX cream: 250 g tube	7612210031878
Green microfiber cloth: for stainless steel	7612210031915
Blue microfiber cloth: for mirror	7612210031908



RECESSED OR WALL MOUNTING? THE CHOICE IS YOURS

With wall-mount and recess-mount models, Franke products permit the greatest flexibility possible in washroom fixtures. Prevention of vandalism, cleaning efficiency and sustainability are increasingly discussed and requested for new washrooms in public, semi-public and commercial spaces.

Recessed mounting:

In addition to prominent product characteristics, there are other aspects to recess-mounted models: Flush mounting offers a reduced surface for wilful destruction and provides a space-saving solution in tight wash station areas and restrooms. Recessed mounting also minimizes cleaning time. An integrated mounting frame greatly simplifies the fitting to both drywall and solid construction frames.

Wall mounting

Special wall mounting brackets enable the installer to complete the installation quickly and securely. The RODAN line's universal hole patterns ensure great installation flexibility, especially when retrofitting the products.



ONE SYSTEM - ONE PARTNER

Franke Washroom Systems offers the possibility of custom combinations of state-of-the-art valve technology and timelessly elegant fixtures made of stainless steel and Miranit. The resulting solutions redefine both the design and operation of sanitary facilities.

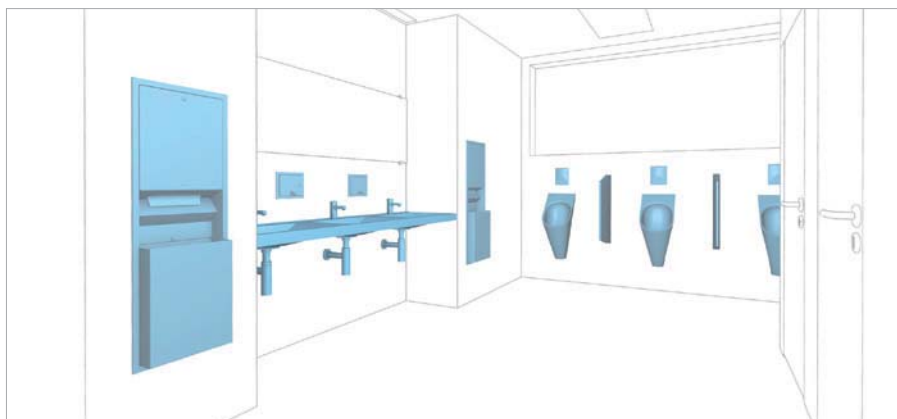

WASHROOM: paper towel dispensers/waste bins, sensor flush valves, soap dispensers, self-closing taps, 3-person recessed wash basin

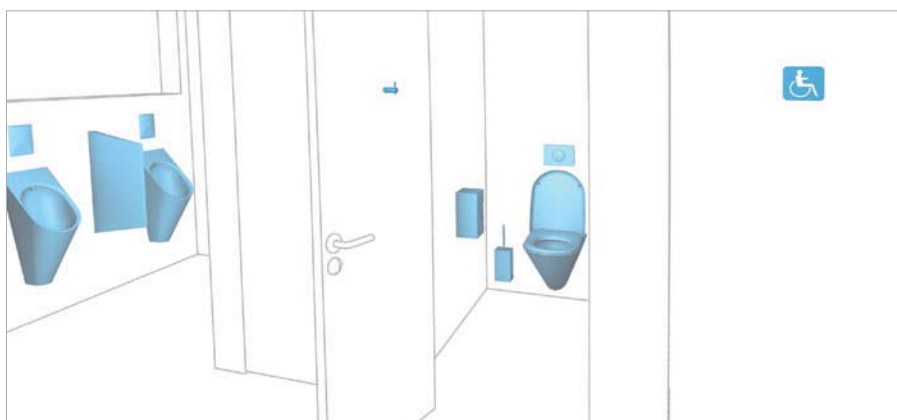

TOILET CABINES/URINAL CABINES: urinals, urinal partition, urinal flush valves, hook, toilet roll holder, toilet brush and brush holder, toilet with seat, flush plate, pictogram

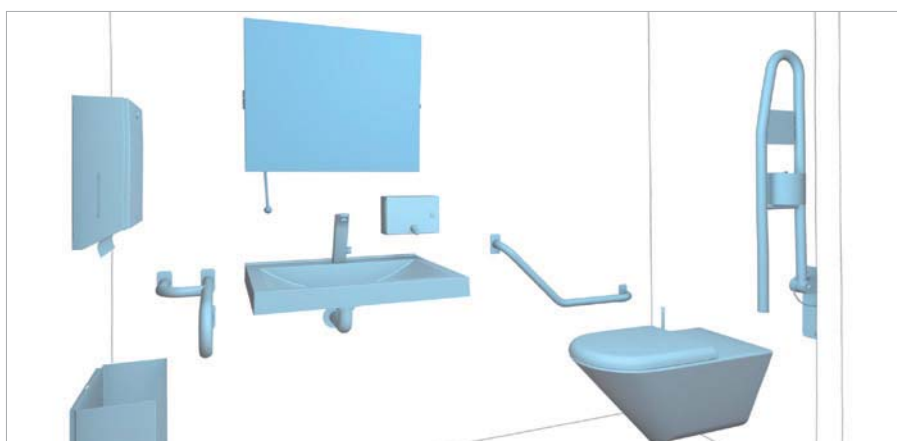

HANDICAP-ACCESSIBLE TOILET CABINE: paper towel dispenser, waste bin, tilted mirror, wall-mounted grab bar, single wash basin, sensor operated tap, soap dispenser, side-mounted hand rail 135°, handicap-accessible toilet with seat, fold-up grab bar with flush actuator



Sample washroom:
equipped with RODAN
recess-mount products,
Miranit multiple wash ba-
sin, self-closing taps, urinal
flush valves, and urinals by
Franke!



18

products with a new design ... that's what you'll find in the new RODAN sanitary line. With 100 years of experience in stainless steel, Franke Washroom Systems delivers coordinated solutions for public, semi-public and commercial sanitary facilities. Functional, high-quality, hygienic products offer professionals the appropriate solution for designing washrooms.

EXPERIENCE THE ADVANTAGES

The timeless design of RODAN stainless steel fixtures with their angular side profiles lends itself to the contemporary decor of heavily frequented washrooms and restrooms. These accessories open to planners and operators the possibility of economical, aesthetic design of customized washroom design.

0.8 mm of durable stainless steel

5-year Franke warranty

23-liter capacity per waste bin

304 AISI stands for high-quality stainless steel (1.4301)

up to 600 paper towels per dispenser

2,000 soap pump operations possible per fill

1,250,000 tested soap pump operations without loss of function



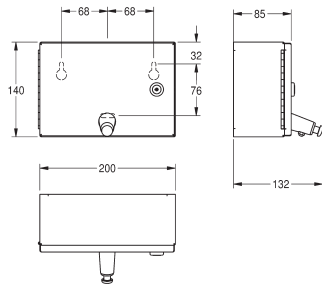

Soap dispenser for wall mounting

Soap dispenser for wall mounting, stainless steel, surface satin finished, material thickness 0.8 mm, flat front cover, cylinder lock with Franke standard key, suitable for liquid soaps and lotions, 1 litre soap tank, push button on front, incl. stainless steel screws and dowels.

200x140x85 mm

RODX619

76 12210067198

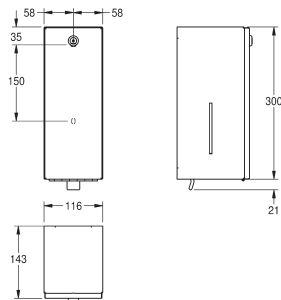

Soap dispenser for wall mounting

Soap dispenser for recessed mounting, stainless steel, surface satin finished, material thickness 0.8 mm, flat front cover, cylinder lock with Franke standard key, suitable for liquid soaps and lotions, 0.8 litre soap tank, plastic dispensing handle, incl. stainless steel screws and dowels

116x321x143 mm

RODX618

7612210067310

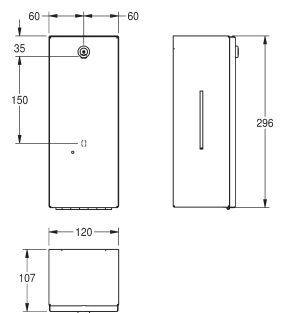

Touch-free soap and disinfectant dispenser for wall mounting

Touch-free soap and disinfectant dispenser for wall mounting, stainless steel, surface satin finished, material thickness 0.8 mm, flat front cover, cylinder lock with Franke standard key, infrared sensor for non-touch operation, LED indicates low-battery status, uses 6 x 1.5V (= 9V) AA alkaline batteries, suitable for liquid soaps, lotions, antiseptic soaps and disinfectants, 0.8-liter soap tank, dispenses 0.6 to 1.1 ml depending on soap, incl. stainless steel screws and dowels

120x295x107 mm

RODX625

Available beginning 06/2010

76 12210067341

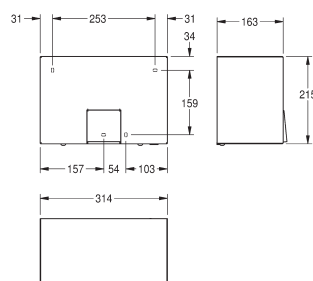

Touch-free warm air hand dryer for wall mounting

Touch-free warm air hand dryer for wall mounting, stainless steel, surface satin finished, material thickness 1.2 mm, infrared sensor for non-touch operation, sensor range adjustable from 10 to 30 cm, cable and plug not included.

Connection voltage: 230 V, 50 Hz

Total power: 2200 W

Heater: 2100 W

Motor: 100 W motor with 2850 RPM

Air volume: 274 m³/h

Air velocity: 15.5 m/s

314x215x163 mm

RODX310

Available beginning 06/2010

76 12210067358

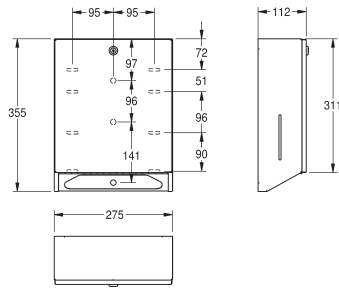

Paper towel dispenser for wall mounting

Paper towel dispenser for wall mounting, stainless steel, surface satin finished, material thickness 0.8 mm, flat front cover, cylinder lock with Franke standard key, inspection windows on sides, loading capacity 500 - 800 paper towels depending on convolution, incl. stainless steel screws and dowels

275x355x112 mm

RODX600

7612210067075

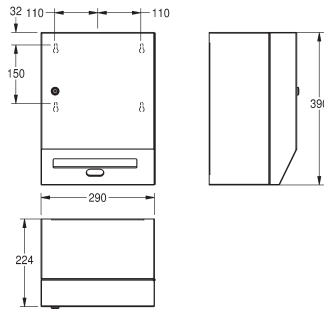

Touch-free paper towel dispenser for wall mounting

Touch-free paper towel dispenser for wall mounting, stainless steel, surface satin finished, material thickness 0.8 mm, flat cover with cylinder lock and standard Franke key, infrared sensor for non-touch operation, integrated tear-off edge, needs four standard D 1.5V batteries, maintenance-free mechanism and easy paper roll change mechanism, for rolls with max. width 210 mm and max. diameter 220 mm, paper length adjustable to 200, 250 and 300 mm, incl. stainless steel screws and dowels

290x390x224 mm

RODX630

Available beginning 06/2010

7612210067372

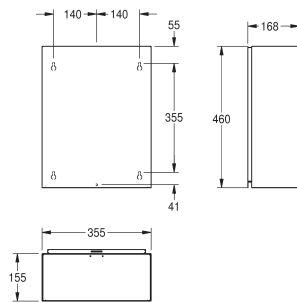

Waste bin for wall mounting

Waste bin for wall mounting, stainless steel, surface satin finished, material thickness 0.8 mm, cylinder lock with Franke standard key, rounded edges, approx. 23 litre capacity, mounting either with mounting bracket or directly onto the wall, incl. stainless steel screws and dowels.

355x460x168 mm

RODX605

7612210067167

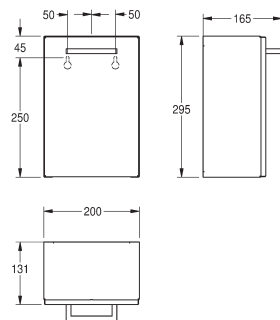

Sanitary towel disposal and waste bin for wall mounting

Sanitary towel disposal and waste bin for wall mounting, stainless steel, surface satin finished, material thickness 0.8 mm, flat front cover, approx. 3.7 litre capacity, removable plastic container inside, incl. stainless steel screws and dowels

200x295x165 mm

RODX611

7612210067334

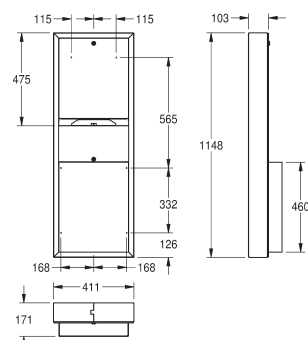

Combination paper towel dispenser/waste bin for wall mounting

Combination paper towel dispenser/waste bin for wall mounting, stainless steel, surface satin finished, material thickness 0.8 mm, flat front cover, cylinder lock with Franke standard key, loading capacity 500 - 800 paper towels depending on brand and folding, waste bin with approx. 23 litre capacity, incl. stainless steel screws and dowels.

411x1148x171 mm

RODX602

7612210067136

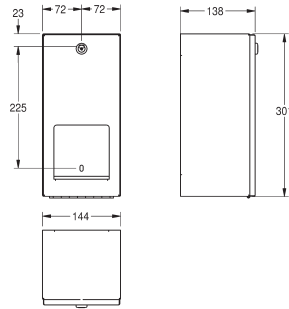

Double toilet roll holder with spindle system for wall mounting

Double toilet roll holder with spindle system for wall mounting, stainless steel, surface satin finished, material thickness 0.8 mm, flat front cover, cylinder lock with Franke standard key, for 2 rolls with max. Ø 120 mm, second roll will be released after consumption of first roll, reserve roll not visible, incl. stainless steel screws and dowels.

144x301x138 mm

RODX672

76 122 10067228

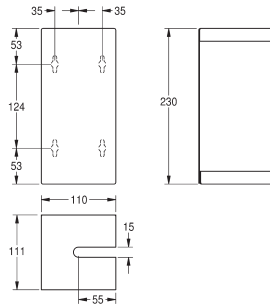

Toilet brush holder for wall mounting

Toilet brush holder for wall mounting, stainless steel, surface satin finished, material thickness 0.8 mm, flat front cover, closed cover to the front, lasered opening for brush, white nylon brush with flushing rim cleaner, withdrawal opening either left or right, depending on mounting, removable plastic drip tray, incl. stainless steel screws and dowels.

110x230x111 mm

RODX687

76 122 10068621

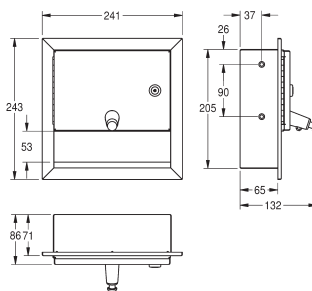

Soap dispenser for recessed mounting

Soap dispenser for recessed mounting, stainless steel, surface satin finished, material thickness 0.8 mm, flat front cover, cylinder lock with Franke standard key, suitable for liquid soaps and lotions, 1 litre soap tank, push button on front, incl. stainless steel screws and dowels.

241x243x86 mm

RODX619E

76 122 10067204

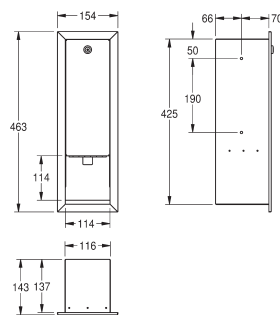

Soap dispenser for recessed mounting

Soap dispenser for recessed mounting, stainless steel, surface satin finished, material thickness 0.8 mm, flat front cover, cylinder lock with Franke standard key, suitable for liquid soaps and lotions, 0.8 litre soap tank, plastic dispensing handle, incl. stainless steel screws and dowels.

154x463x143 mm

RODX618E

76 122 10067327

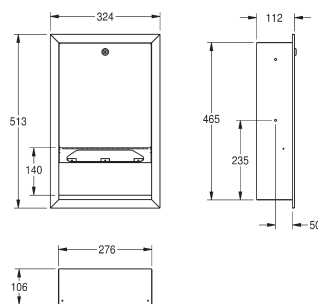

Paper towel dispenser for recessed mounting

Paper towel dispenser for recessed mounting, stainless steel, surface satin finished, material thickness 0.8 mm, flat front cover, cylinder lock with Franke standard key, loading capacity 500 - 800 paper towels depending on convolution, incl. stainless steel screws and dowels.

324x513x112 mm

RODX600E

76 122 10067099

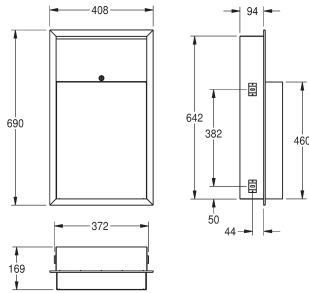

Waste bin for recessed mounting

Waste bin for recessed mounting, stainless steel, surface satin finished, material thickness 0.8 mm, rounded edges, cylinder lock with Franke standard key, approx. 23 litre capacity, mounting with in-wall frame, incl. stainless steel screws and dowels.

408x690x169 mm

RODX605E

7612210067174

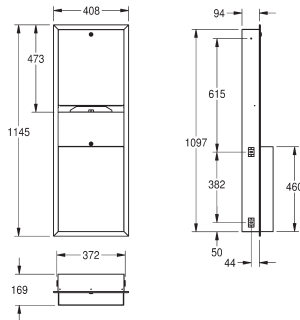

Combination paper towel dispenser/waste bin for recessed mounting

Combination paper towel dispenser/waste bin for recessed mounting, stainless steel, surface satin finished, material thickness 0.8 mm, flat front cover, cylinder lock with Franke standard key, loading capacity 500 - 800 paper towels depending on brand and folding, waste bin with approx. 23 litre capacity, incl. stainless steel screws and dowels.

408x1145x169 mm

RODX602E

7612210067143

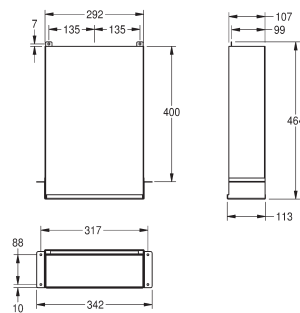

Paper towel dispenser for hidden mounting

Paper towel dispenser for hidden mounting behind wall and mirror, stainless steel, surface satin finished, material thickness 0.8 mm, capacity for 600 C-fold or 800 multifold paper towels, filling from bottom, incl. stainless steel screws and dowels

342x464x113 mm

RODX600ME

7612210067297

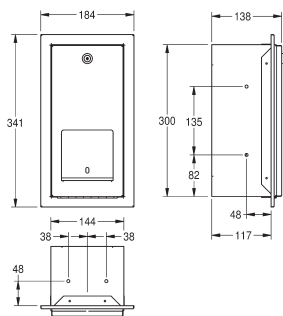

Double toilet roll holder with spindle system for recessed mounting

Recessed double toilet roll holder with spindle system for recessed mounting, stainless steel, surface satin finished, material thickness 0.8 mm, flat front cover, cylinder lock with Franke standard key, for 2 rolls with max. Ø 120 mm, second roll will be released after consumption of first roll, reserve roll not visible, incl. stainless steel screws and dowels.

184x341x138 mm

RODX672E

7612210067235

Consumable supplies

Liquid soap 1 litre
suitable for: RODX618, RODX618E, RODX619, RODX619E
SO1L

7612210003196

Liquid soap 10 litres, in canister
suitable for: RODX618, RODX618E, RODX619, RODX619E
SO10L

7612210003202

Folded paper towels 168 towels/package
suitable for: RODX600, RODX600E, RODX600ME,
RODX602, RODX602E

FH68

7612210000393

ONE-STOP SHOPPING EXAMPLE «RODAN»



Z-CMPX140
Wall bracket set



Z-CMPX140
Wall bracket set



CMPX135
Installation element for urinals with wall-mounted flush valve (electronic or manual)

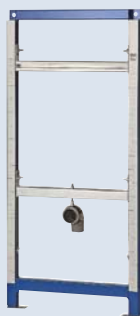

CMPX137
Installation element for waterfree urinals



AQRE431
Optoelectronically controlled urinal flush valve, battery operation



AQRE432
Optoelectronically controlled urinal flush valve with integrated transformer



CMPX538
Urinal



CMPX538WF
Waterfree urinal

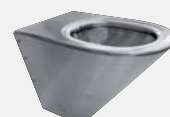

CMPX592B
Toilet, seat and cover



AQUA503
Flush control with piezo button

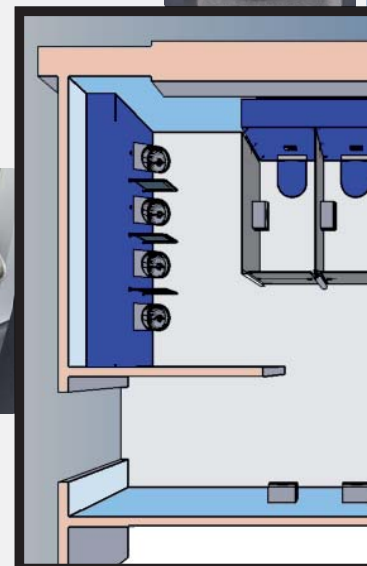

RODX605
Waste bin



Fittings level

Installation elements



CMPX140
Installation system with
cistern for toilet system



AQUA504
Flush control with
opto-electronic sensors



RODX672
Double toilet roll holder



M500HD
Mirror



RODX618
Soap dispenser

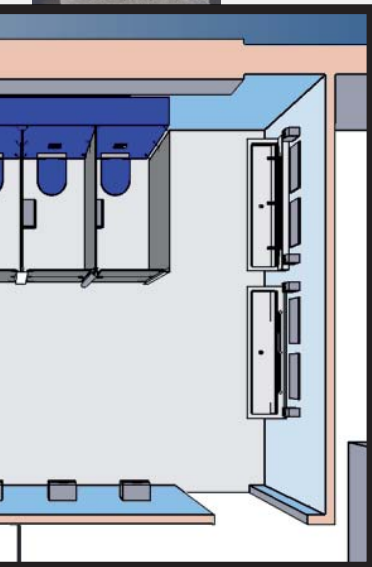

SANX180
Wash trough for 3 users

Rear panel with backsplash for
3 users and optoelectronically
controlled wall-mounted faucets



RODX310
Hand dryer



AQUA109
Opto-electronic
sensor



CMPX150
Installation element
for wash basins



Sample washroom:
equipped with STRATOS
recess-mounted products,
Miranit multiple wash
basin, self-closing taps,
flush valves, and urinals by
Franke!

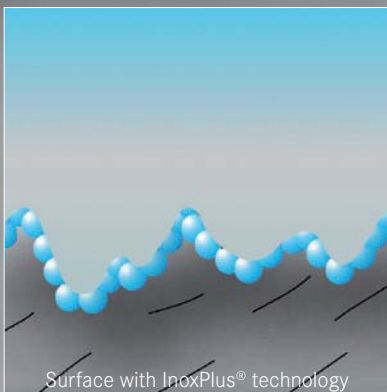

Surface with InoxPlus® technology

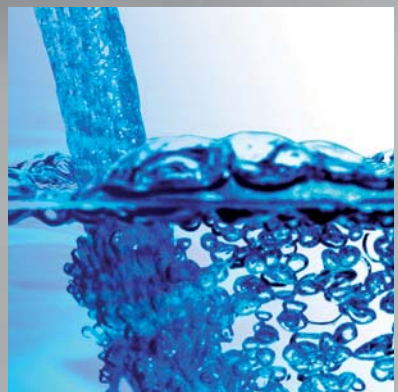

40

wall-mounted and recess-mounted products make up the well-known STRATOS. Effective immediately, the front surfaces of these products are being refined with the proven InoxPlus® technology. In this process, nanoparticles interlock with the molecules of the metal surface and nestle closely against microscopic imperfections. The resulting tight structure makes fingerprints almost invisible. The washroom stays clean longer, and cleaning is significantly easier.

YOU CAN RELY ON PROVEN DESIGN

The InoxPlus® surface refinement was first used in mass production in 2004 with the high-end Franke XINOX line. In recent years, the technology has proven its value and enjoys great popularity in hotels, administration buildings and even sports arenas worldwide.

1 surface-refinement process yields convenient cleaning

1.5 mm durable stainless steel front

5-year Franke warranty

11 recessed models and

29 wall-mounted models

120,000 installed models using the example of the STRX618

1,250,000 tested soap pump operations without loss of function



Franke STRATOS

IMAGE

TYPE/MODEL

ITEM NUMBER

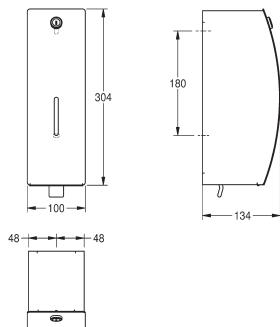

Soap dispenser for wall mounting

Soap dispenser for wall mounting, stainless steel, surface satin finished, front with InoxPlus® surface refinement for the reduction of fingerprints and better cleaning characteristics (easy to clean), material thickness 1.5 mm, curved front cover, cylinder lock with Franke standard key, inspection window on front, suitable for liquid soaps and lotions, 0.8 litre soap tank, plastic dispensing handle, incl. stainless steel screws and dowels.

100x304x134 mm

STR618



7612210006531

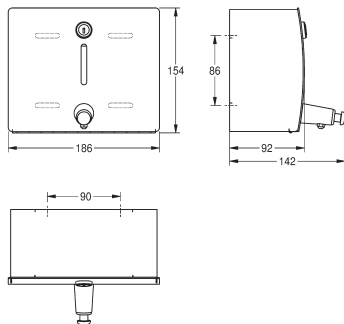

Soap dispenser for wall mounting

Soap dispenser for wall mounting, stainless steel, surface satin finished, front with InoxPlus® surface refinement for the reduction of fingerprints and better cleaning characteristics (easy to clean), material thickness 1.5 mm, curved front cover, cylinder lock with Franke standard key, inspection window on front, suitable for liquid soaps and lotions, 1 litre soap tank, push button on front, incl. stainless steel screws and dowels.

186x154x92 mm

STR619



7612210008566

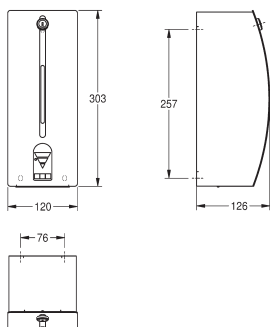

Touch-free soap dispenser for wall mounting

Touch-free soap dispenser for wall mounting, stainless steel, surface satin finished, front with InoxPlus® surface refinement for the reduction of fingerprints and better cleaning characteristics (easy to clean), material thickness 1.5 mm, curved front cover, cylinder lock with Franke standard key, infrared sensor for non-touch operation, integrated shut-off when housing is opened, LED indicates low-battery status, incl. 6 x 1.5V (= 9V) AA alkaline batteries, suitable for liquid soaps and lotions, 0.8 litre soap tank, dispenses 0.6 to 1.1 ml depending on soap, incl. stainless steel screws and dowels.

120x303x126 mm

STR625



7612210050251

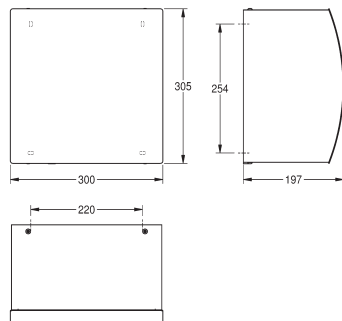

Touch-free warm air hand dryer for wall mounting

Touch-free hand dryer for wall mounting, electronic warm air hand dryer, stainless steel, surface satin finished, front with InoxPlus® surface refinement for the reduction of fingerprints and better cleaning characteristics (easy to clean), material thickness 1.5 mm, curved front cover, Infrared sensor for non-touch operation, sensor range adjustable from 5 to 33 cm, automatic power shut-off after 60 seconds, due to the extreme high, adjustable air velocity the drying time is shortened strongly, cable and plug not included.

Connection voltage: 230 V, 50 Hz

Total power: 1500 W

Heater: 800 W

Motor: 700 W motor

Air volume: 120 m³/h

Air velocity: 75 - 110 m/s

300x305x197 mm

STRX210



7612210052231

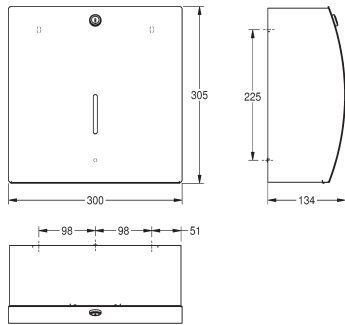

Paper towel dispenser for wall mounting

Paper towel dispenser for wall mounting, stainless steel, surface satin finished, front with InoxPlus® surface refinement for the reduction of fingerprints and better cleaning characteristics (easy to clean), material thickness 1.5 mm, curved front cover, inspection window, cylinder lock with Franke standard key, loading capacity 300 - 400 Z-fold towels, incl. stainless steel screws and dowels.

300x305x134 mm

STRX600



7612210006425

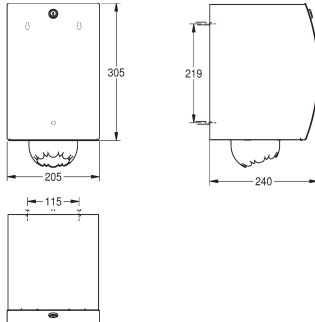

Centerfeed paper roll box for wall mounting

Centerfeed paper roll box for wall mounting, stainless steel, surface satin finished, front with InoxPlus® surface refinement for the reduction of fingerprints and better cleaning characteristics (easy to clean), material thickness 1.5 mm, curved front cover, cylinder lock with Franke standard key, for paper rolls with max. Ø 190 mm and max. height of 250 mm, only for centerfeed paper rolls, integrated tear-off edge and strain relief avoiding paper tear-off within casing, incl. stainless steel screws and dowels.

205x305x240 mm

STRX635



7612210055560

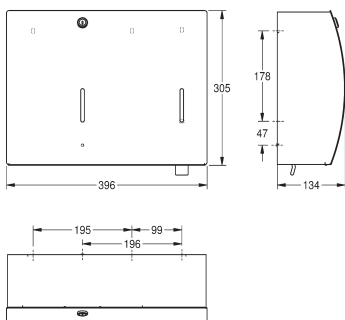

Combination paper towel/soap dispenser for wall mounting

Combination paper towel dispenser/soap dispenser for wall mounting, stainless steel, surface satin finished, front with InoxPlus® surface refinement for the reduction of fingerprints and better cleaning characteristics (easy to clean), material thickness 1.5 mm, curved front cover, with two inspection windows, cylinder lock with Franke standard key, paper towel dispenser with loading capacity 300 - 400 Z-fold towels, soap dispenser suitable for liquid soaps and lotions as well as antiseptic soaps, 0.8 litre soap tank, plastic dispensing handle, incl. stainless steel screws and dowels.

396x305x134 mm

STRX601



7612210006760

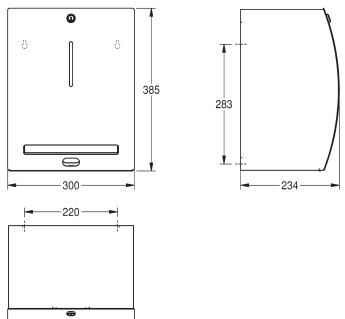

Touch-free paper towel dispenser for wall mounting

Touch-free paper towel dispenser for wall mounting, stainless steel, surface satin finished, front with InoxPlus® surface refinement for the reduction of fingerprints and better cleaning characteristics (easy to clean), material thickness 1.5 mm, curved front cover, cylinder lock with Franke standard key, Infrared sensor for non-touch operation, integrated tear-off edge, incl. four pieces standard D 1.5 V (= 6 V) batteries, maintenance free mechanic and easy paper roll change mechanism, for rolls with max. width 205 mm and max. diameter 220 mm, paper length adjustable to 200, 250 and 300 mm, incl. stainless steel screws and dowels.

300x385x234 mm

STRX630



7612210055553

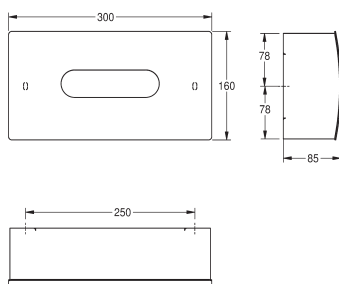

Face towel dispenser for wall mounting

Face towel dispenser for wall mounting, stainless steel, surface satin finished, front with InoxPlus® surface refinement for the reduction of fingerprints and better cleaning characteristics (easy to clean), material thickness 1.5 mm, curved front cover with oval aperture to dispense standard facial tissues, incl. stainless steel screws and dowels.

300x160x85 mm

STR650



76 122 10006562

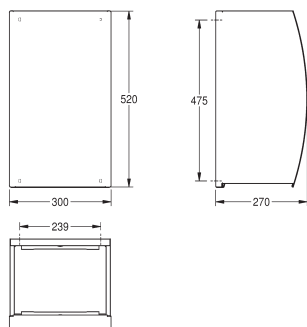

Waste bin for wall mounting

Waste bin for wall mounting, stainless steel, surface satin finished, front with InoxPlus® surface refinement for the reduction of fingerprints and better cleaning characteristics (easy to clean), material thickness 1.5 mm, curved front cover, cylinder lock with Franke standard key, approx. 34 litre capacity, integrated bag holder, incl. stainless steel screws and dowels.

300x520x270 mm

STR605



76 122 10006517

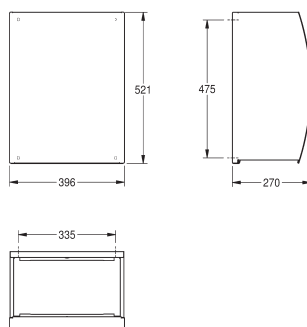

Waste bin for wall mounting

Waste bin for wall mounting, stainless steel, surface satin finished, front with InoxPlus® surface refinement for the reduction of fingerprints and better cleaning characteristics (easy to clean), material thickness 1.5 mm, curved front cover, cylinder lock with Franke standard key, approx. 45 litre capacity, integrated bag holder, incl. stainless steel screws and dowels.

396x521x270 mm

STR607



76 122 10006463

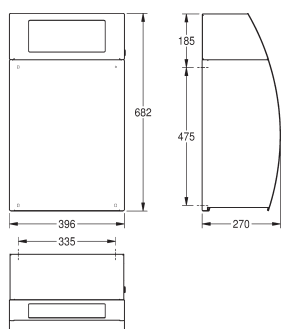

Folding self-closing lid for waste bin STR607

Folding self-closing lid for waste bin STR607, stainless steel, surface satin finished, front with InoxPlus® surface refinement for the reduction of fingerprints and better cleaning characteristics (easy to clean), material thickness 1.5 mm, curved front with self-closing lid, cylinder lock with Franke standard key, incl. stainless steel screws and dowels, price without waste bin.

396x161x229 mm

STR608



76 122 10006722

Figure and drawing with waste bin STR607

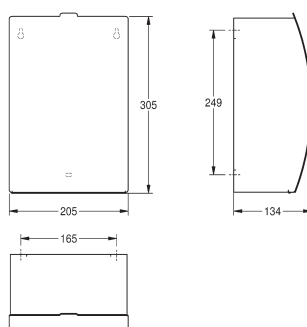

Sanitary towel disposal and waste bin for wall mounting

Sanitary towel disposal and waste bin for wall mounting, stainless steel, surface satin finished, front with InoxPlus® surface refinement for the reduction of fingerprints and better cleaning characteristics (easy to clean), material thickness 1.5 mm, curved front cover, approx. 3.8 litre capacity, folding self-closing lid with stainless steel piano hinge, removable plastic container inside, incl. stainless steel screws and dowels.

205x305x134 mm

STR611



76 122 10006524

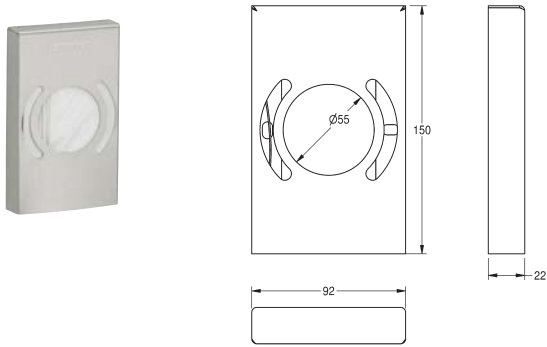

Hygiene bag dispenser for wall mounting

Hygiene bag dispenser for wall mounting, stainless steel, surface satin finished, front with InoxPlus® surface characteristic for the reduction of fingerprints and better cleaning characteristic (easy to clean), material thickness 1.2 mm, edges not welded, inboard lug to hold package, withdrawal from front, incl. premounted double-sided self-adhesive tap and stainless steel screws and dowels, incl. acetone rag to clean bonding surface.

92x150x22 mm

HBD191

7612210051746

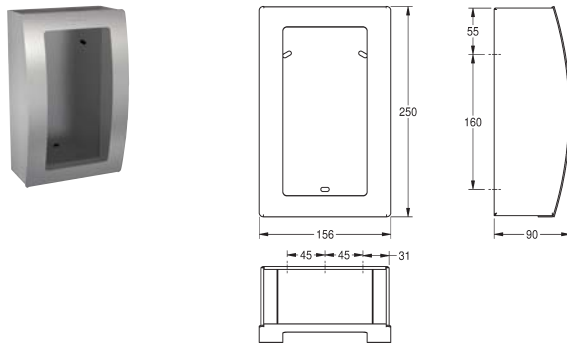

Hygiene bag dispenser for wall mounting

Hygiene bag dispenser for wall mounting, stainless steel, surface satin finished, front with InoxPlus® surface refinement for the reduction of fingerprints and better cleaning characteristics (easy to clean), material thickness 1.2/1.5 mm, curved front cover, incl. stainless steel screws and dowels.

156x250x90 mm

STRX615



7612210006579

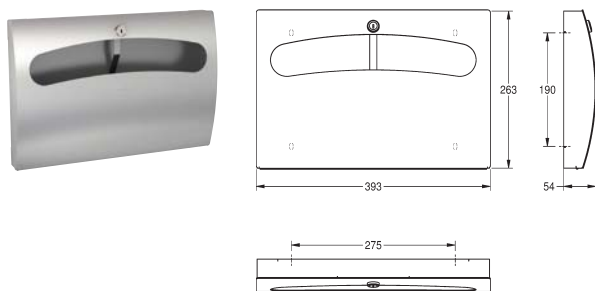

Toilet seat paper dispenser for wall mounting

Toilet seat paper dispenser for wall mounting, stainless steel, surface satin finished, front with InoxPlus® surface refinement for the reduction of fingerprints and better cleaning characteristics (easy to clean), material thickness 1.5 mm, curved front cover with oval aperture, cylinder lock with Franke standard key, for Franke seat paper or others, incl. stainless steel screws and dowels.

393x263x54 mm

STRX680



7612210010323

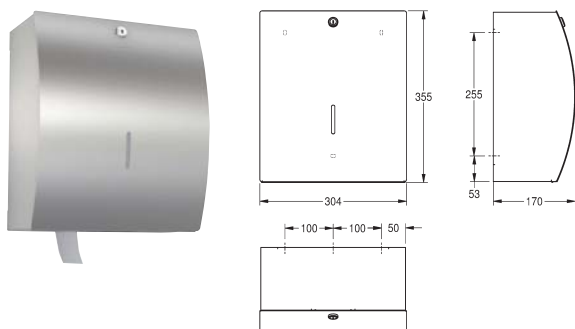

Jumbo toilet roll holder for wall mounting

Jumbo toilet roll holder for wall mounting, stainless steel, surface satin finished, front with InoxPlus® surface refinement for the reduction of fingerprints and better cleaning characteristics (easy to clean), material thickness 1.5 mm, curved front cover, closed housing with inspection window, paper dispensing with two serrated tear-off edges, cylinder lock with Franke standard key, for one jumbo roll with max Ø 295 mm, incl. stainless steel screws and dowels.

304x355x170 mm

STRX670



7612210010316

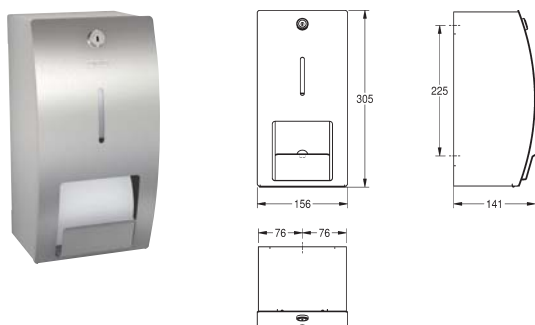

Double toilet roll holder for wall mounting

Double toilet roll holder for wall mounting, stainless steel, surface satin finished, front with InoxPlus® surface refinement for the reduction of fingerprints and better cleaning characteristics (easy to clean), material thickness 1.5 mm, curved front cover, closed housing with inspection window, cylinder lock with Franke standard key, for two rolls up to max Ø 120 mm, second roll falls when clip is folded up into dispense position, without spindle system, incl. stainless steel screws and dowels.

156x305x141 mm

STRX671



7612210006432

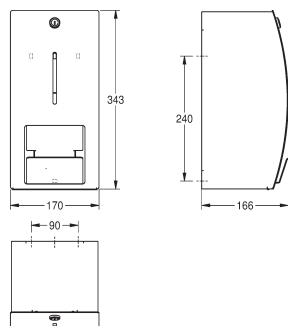

Double toilet roll holder without spindle system for wall mounting

Double toilet roll holder for wall mounting, stainless steel, surface satin finished, front with InoxPlus® surface refinement for the reduction of fingerprints and better cleaning characteristics (easy to clean), material thickness 1.5 mm, curved front cover, closed housing with inspection window, cylinder lock with Franke standard key, for two rolls up to max Ø 140 mm, second roll falls when clip is folded up into dispense position, without spindle system, incl. stainless steel screws and dowels.

170x343x166 mm

STRX671L



76 122 10030963

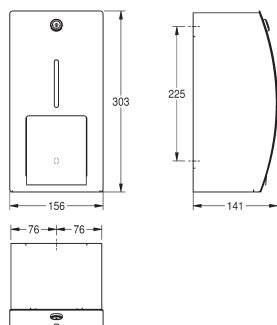

Double toilet roll holder with spindle system for wall mounting

Double toilet roll holder for wall mounting, stainless steel, surface satin finished, front with InoxPlus® surface refinement for the reduction of fingerprints and better cleaning characteristics (easy to clean), material thickness 1.5 mm, curved front cover, closed housing, cylinder lock with Franke standard key, for two rolls up to max Ø 120 mm, second roll will be released after consumption of first roll, second roll not visible, with spindle system, incl. stainless steel screws and dowels.

156x303x141 mm

STRX672



76 122 10009501

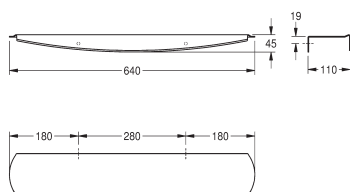

Shelf for wall mounting

Shelf for wall mounting, stainless steel, surface satin finished, front with InoxPlus® surface refinement for the reduction of fingerprints and better cleaning characteristics (easy to clean), material thickness 2 mm, rounded edges, protection edge at front, incl. stainless steel screws and dowels.

640x110x45 mm

STRX623



76 122 10006609

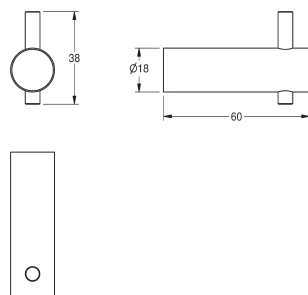

Hook for wall mounting

Hook for wall mounting, stainless steel, surface satin finished, 18 mm pipe diameter, drilled hole on bottom for fixation, incl. stainless steel screws and dowels.

18x60 mm

STRX692

76 122 10051760

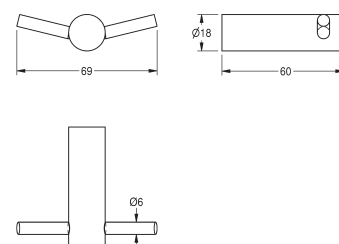

Double hook for wall mounting

Double hook for wall mounting, stainless steel, surface satin finished, 18 mm pipe diameter, drilled hole on bottom for fixation, incl. stainless steel screws and dowels.

18x60 mm

STRX694

76 122 10051791

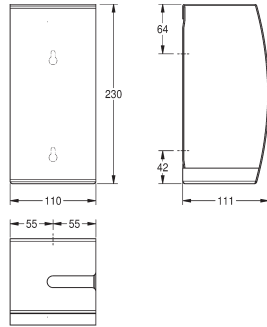

Toilet brush holder for wall mounting

Toilet brush holder for wall mounting, stainless steel, surface satin finished, front with InoxPlus® surface refinement for the reduction of fingerprints and better cleaning characteristics (easy to clean), material thickness 1.5 mm, curved front cover, white nylon brush with flushing rim cleaner, removable plastic drip tray, incl. stainless steel screws and dowels.

110x230x111 mm

STRX687



7612210006548

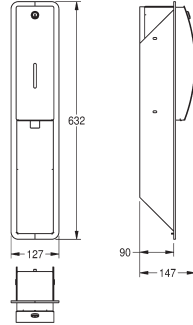

Soap dispenser for recessed mounting

Soap dispenser for recessed mounting, stainless steel, surface satin finished, front with InoxPlus® surface refinement for the reduction of fingerprints and better cleaning characteristics (easy to clean), material thickness 1.5 mm, curved front cover, cylinder lock with Franke standard key, inspection window on front, suitable for liquid soaps and lotions as well as antiseptic soaps, 0.8 litre soap tank, plastic dispensing handle, incl. stainless steel screws and dowels.

127x632x147 mm

STRX618E



7612210006654

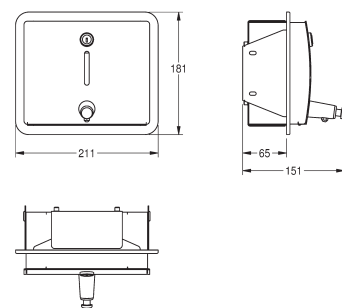

Soap dispenser for recessed mounting

Soap dispenser for recessed mounting, stainless steel, surface satin finished, front with InoxPlus® surface refinement for the reduction of fingerprints and better cleaning characteristics (easy to clean), material thickness 1.5 mm, curved front cover, cylinder lock with Franke standard key, inspection window on front, suitable for liquid soaps and lotions as well as antiseptic soaps, 1 litre soap tank, push button on front, incl. stainless steel screws and dowels.

211x181x101 mm

STRX619E



7612210013720

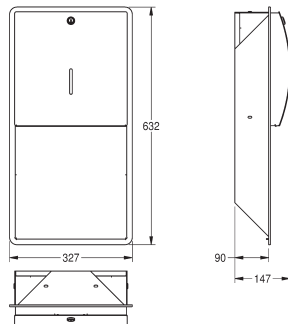

Paper towel dispenser for recessed mounting

Paper towel dispenser for recessed mounting, stainless steel, surface satin finished, front with InoxPlus® surface refinement for the reduction of fingerprints and better cleaning characteristics (easy to clean), material thickness 1.5 mm, curved front cover, inspection window, cylinder lock with Franke standard key, loading capacity 300 - 400 Z-fold towels, incl. stainless steel screws and dowels.

327x632x147 mm

STRX600E



7612210006661

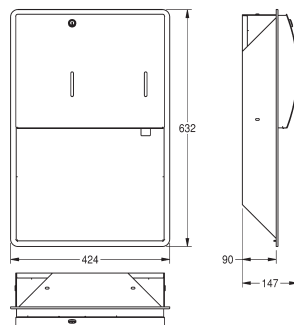

Combination paper towel/soap dispenser for recessed mounting

Combination paper towel dispenser/soap dispenser for recessed mounting, stainless steel, surface satin finished, front with InoxPlus® surface refinement for the reduction of fingerprints and better cleaning characteristics (easy to clean), material thickness 1.5 mm, curved front cover, with two inspection windows, both parts with cylinder lock and Franke standard key, paper towel dispenser with loading capacity 300 - 400 Z-fold towels, soap dispenser suitable for liquid soaps and lotions as well as antiseptic soaps, 0.8 litre soap tank, plastic dispensing handle, incl. stainless steel screws and dowels.

424x632x147 mm

STRX601E



7612210006791

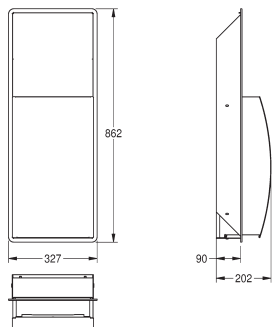

Waste bin for recessed mounting

Waste bin for recessed mounting, stainless steel, surface satin finished, front with InoxPlus® surface refinement for the reduction of fingerprints and better cleaning characteristics (easy to clean), material thickness 1.5 mm, curved front cover, cylinder lock with Franke standard key, approx. 22 litre capacity, integrated bag holder, incl. stainless steel screws and dowels.

327x862x202 mm

STRX605E



76 122 10006678

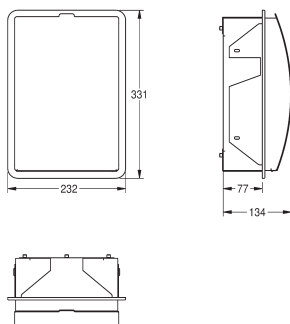

Sanitary towel disposal and waste bin for recessed mounting

Sanitary towel disposal and waste bin for recessed mounting, stainless steel, surface satin finished, front with InoxPlus® surface refinement for the reduction of fingerprints and better cleaning characteristics (easy to clean), material thickness 1.5 mm, curved front cover, approx. 3.8 litre capacity, folding self-closing lid with stainless steel piano hinge, removable plastic container inside, incl. stainless steel screws and dowels.

232x331x134 mm

STRX611E



76 122 10006715

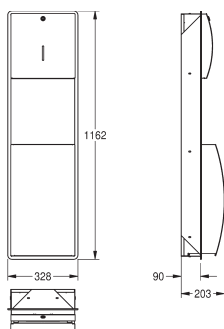

Combination paper towel dispenser/waste bin for recessed mounting

Combination paper towel dispenser/waste bin for recessed mounting, stainless steel, surface satin finished, front with InoxPlus® surface refinement for the reduction of fingerprints and better cleaning characteristics (easy to clean), material thickness 1.5 mm, curved front cover, cylinder lock with Franke standard key, inspection windows on front, loading capacity 300 - 400 Z-fold towels, waste bin with approx. 22 litre capacity, integrated bag holder, incl. stainless steel screws and dowels.

328x1162x203 mm

STRX602E



76 122 10006784

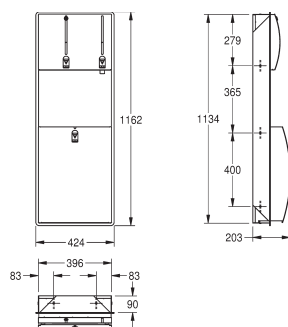

Combination paper towel dispenser, soap dispenser and waste bin for recessed mounting

Combination paper towel dispenser, soap dispenser and waste bin for recessed mounting, stainless steel, surface satin finished, front with InoxPlus® surface refinement for the reduction of fingerprints and better cleaning characteristics (easy to clean), material thickness 1.5 mm, curved front cover, with two inspection windows, with cylinder lock and Franke standard key, paper towel dispenser with loading capacity 300 - 400 Z-fold towels, soap dispenser suitable for liquid soaps and lotions as well as antiseptic soaps, 0.8 litre soap tank, plastic dispensing handle, waste bin with approx. 29 litre capacity, integrated bag holder, incl. stainless steel screws and dowels.

424x1162x203 mm

STRX617E



76 122 10006807



Additional products without InoxPlus® technology

Pictograms: BS630 / BS631 / BS632

Ash tray: BS640

Toilet roll holder: BS677

IMAGE

TYPE/MODEL

ITEM NUMBER

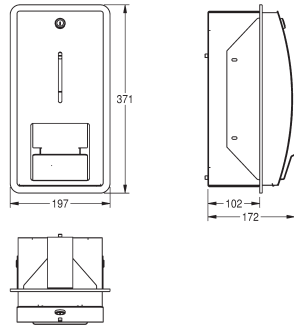

Double toilet roll holder for recessed mounting

Double toilet roll holder for recessed mounting, stainless steel, surface satin finished, front with InoxPlus® surface refinement for the reduction of fingerprints and better cleaning characteristics (easy to clean), material thickness 1.5 mm, curved front cover, closed housing with inspection window, cylinder lock with Franke standard key, for two rolls up to max Ø 120 mm, second roll falls when clip is folded up into dispense position, without spindle system, incl. stainless steel screws and dowels.

197x371x172 mm

STRX671E



7612210006708

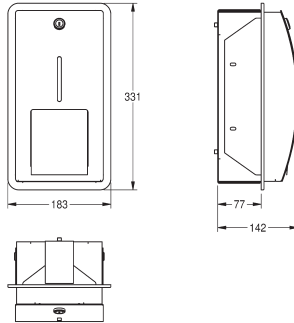

Double toilet roll holder with spindle system for recessed mounting

Double toilet roll holder for recessed mounting, stainless steel, surface satin finished, front with InoxPlus® surface refinement for the reduction of fingerprints and better cleaning characteristics (easy to clean), material thickness 1.5 mm, curved front cover, closed housing with inspection window, cylinder lock with Franke standard key, for two rolls up to max Ø 120 mm, second roll will be released after consumption of first roll, second roll not visible, with spindle system, incl. stainless steel screws and dowels.

183x331x142 mm

STRX672E



7612210009518

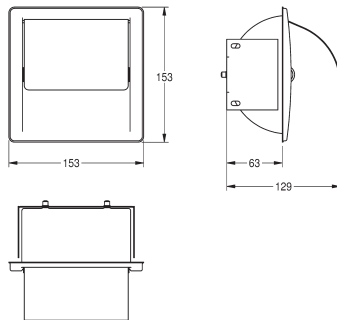

Toilet roll holder for recessed mounting

Toilet roll holder for recessed mounting, stainless steel, surface satin finished, material thickness 0.8 mm, curved lid, for one roll up to max. 130 mm wide, incl. stainless steel screws and dowels.

153x153x73 mm

STRX673E

7612210015069

Consumable supplies

Liquid soap 1 litre
suitable for: STRX618, STRX619, STRX625, STRX601,
STRX618E, STRX619E, STRX601E, STRX617E

SO1L

7612210003196

Liquid soap 10 litres, in canister
suitable for: STRX618, STRX619, STRX625, STRX601,
STRX618E, STRX619E, STRX601E, STRX617E

SO10L

7612210003202

Folded paper towels 168 towels/package
suitable for: STRX601, STRX600, STRX601E, STRX600E,
STRX602E, STRX617E

FH68

7612210000393

Seat paper 200 pcs./package
suitable for: STRX680

E-STRX680

7612210015717

Plastic hygiene bag 30 bags/package
suitable for: HBD191

HBD191B

7612210053542

Paper hygiene bag 100 bags/package
suitable for: STRX615

HB140

7612210018527

ONE-STOP SHOPPING EXAMPLE «STRATOS»



CMPX 135
Installation element for urinals with wall-mounted flush valve (electronic or manual)

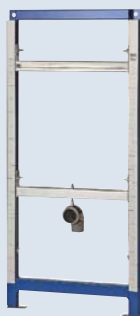

CMPX 137
Installation element for waterfree urinals



AQRE 431
Optoelectronically controlled urinal flush valve, battery operation



AQRE 432
Optoelectronically controlled urinal flush valve with integrated transformer

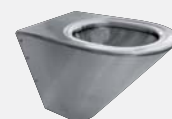

CMPX 592B
Toilet, seat and cover



AQUA 503
Flush control with piezo button

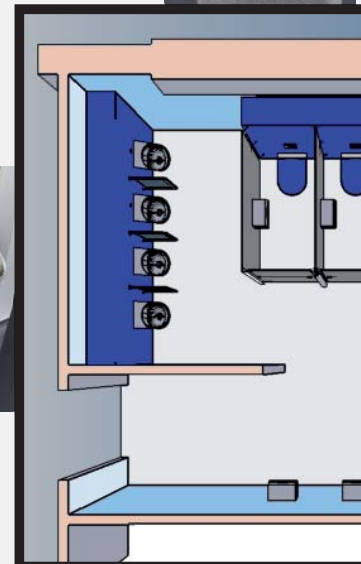

Fittings level

Installation elements



CMPX140
Installation system with
cistern for toilet system



AQUA504
Flush control with
opto-electronic sensors



STRX670
Jumbo toilet roll holder



M500HD
Mirror



STRX618
Soap dispenser

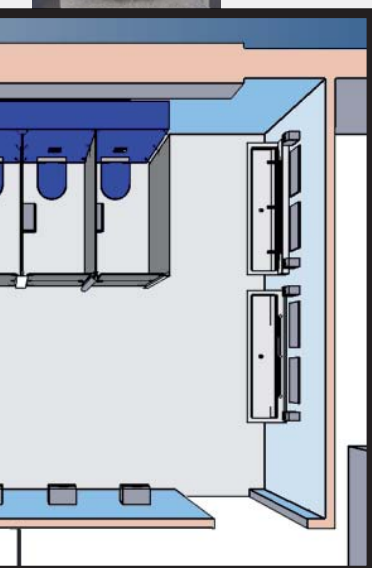

SANX180
Wash trough for 3 users

Rear panel with backsplash for
3 users and optoelectronically
controlled wall-mounted faucets



STRX210
Hand dryer









AQUA109
Opto-electronic
sensor



CMPX150
Installation element
for wash basins

ONE-STOP SHOPPING SMART HYGIENE SOLUTIONS

Franke Washroom Systems offers a wide selection of products for various uses. From wash basins, faucets, shower trays, toilets and urinals to wash basins through to fixtures of all types. Planned and produced by experienced Franke experts who bring their technical know-how to collaborations with architects, planners and other partners in order to realize individual Smart Hygiene Solutions.

	Accessoires Mobility aids	Wash troughs Wash basins Drinking fountains	Urinals Toilets Shower trays Partitions	Sinks Multipurpose sinks Commercial sinks	Wash basin taps Flush valves Shower taps Installation elements	Water-management system	Customized solutions
Industry Commercial	STRATOS RODAN CHRONOS	SATURN ANIMA	CAMPUS	SIRIUS MAXIMA	AQUA AQUAFIX	AQUA3000 open	We'll be happy to advise you!
Office administration	XINOX STRATOS RODAN CONTINA	ANIMA MIRANIT RONDO	CAMPUS	SIRIUS	AQUA AQUAFIX	AQUA3000 open	
Sports Culture Leisure Exhibition	XINOX STRATOS RODAN CONTINA	MIRANIT RONDO	CAMPUS	SIRIUS	AQUA AQUAFIX	AQUA3000 open	
Police Military Prison	HEAVY-DUTY	HEAVY-DUTY MIRANIT	HEAVY-DUTY	MAXIMA	AQUA AQUAFIX	AQUA3000 open	
Hotel Train station Camping Airport	XINOX STRATOS RODAN HEAVY-DUTY CONTINA	HEAVY-DUTY MIRANIT ANIMA RONDO	CAMPUS HEAVY-DUTY	SIRIUS MAXIMA	AQUA AQUAFIX	AQUA3000 open	
Education Care Health	STRATOS RODAN CONTINA	SATURN RONDO MIRANIT	CAMPUS	SIRIUS MAXIMA	AQUA AQUAFIX	AQUA3000 open	
Train Ship Airplane	RODAN HEAVY-DUTY CONTINA	ANIMA	CAMPUS HEAVY-DUTY	no application	AQUA AQUAFIX	no application	
							

FRANKE GROUP

ONE PARTNER WORLDWIDE

Franke Washroom Systems is part of the worldwide acting Franke Gruppe with headquarters in Aarburg, Switzerland. 11,000 people are employed in more than 70 subsidiaries in 40 countries. Franke generates consolidated sales of approx. CHF 2.5 billion per year (EUR 1.7 billion).



Close to our customers. Worldwide.

Other Franke Group Activities in addition to Washroom Systems:



Kitchen Systems
is the world's leading provider of intelligent systems for domestic kitchens, trusted by more users in more kitchens worldwide than any other manufacturer.



Foodservice Systems
is the world's leading provider of comprehensive systems and services for the food service industry worldwide.



Coffee Systems
is a world leading provider of intelligent coffee systems.



Beverage Systems
is the world's leading provider of intelligent beverage systems.



Other Activities:
Franke Industrie AG and Franke Werkzeugbau AG hold leading position in international niche markets.

Franke Washroom Systems
franke.ws@franke.com
www.franke-ws.com

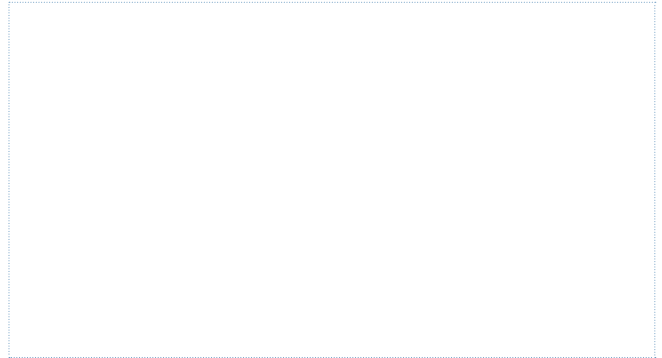

ACC INT / 05.2010 / EN / Changes in dimensions, construction and models reserved.



WASHROOM
SYSTEMS