

## STANDARD MAINTENANCE AND TROUBLESHOOTING

### REPLACING THE CARTRIDGE

1. Shut off the water supply to the faucet.
2. Turn on the faucet briefly to relieve any pressure inside the faucet.
3. Move the faucet handle to the " OFF" position.
4. Remove the cap C from the lever handle A.
5. Remove the screw B using an allen key.
6. Pull the lever handle A from the faucet body .
7. Unscrew the cap D off of the lock nut E.
8. Unscrew the cartridge lock nut E.
9. Lift ceramic disk cartridge F from the body and repalce it with a new one. Ensure the two lugs on bottom of the cartridge sit properly in the allocated holes at the base of the body.
10. Re-assemble faucet in reverse order.
11. Test for leakage.

### GENERAL MAINTENANCE

Clean aerator periodically for any buildup .  
Do not use harsh detergents, solvents, chemical agents, metallic sponges, etc. that could harm the surface and damage the finish.  
Clean only with a soft sponge and soapy water.  
Do not store chemicals or cleaning agents in the immediate vicinity of the faucet and connection hoses. Chemical vapors could cause damage.

### SPARE / REPLACEMENT LIST

A+B+C+G.	Handle assembly	F5206*
B+C.	Screw+Cap	F5207
D.	Cap	F3802*
E.	Lock nut	F3803
F.	Cartridge	F3804
H.	Pull out hose	F3805
I.	Weight	F3102
J.	Check Valve 1.75 gpm	F5208
K.	Pull out spray	F5209*
L.	Escutcheon	F5210*
M.	Mounting Hardware Kit	F3110
N.	Supply hoses	F3809
O.	Pull out supply hose	F5205
P.	Fixing Kit	F3125

\*Must specify finish  
CH chrome  
SN satin nickel  
PN polished nickel  
MB matt black

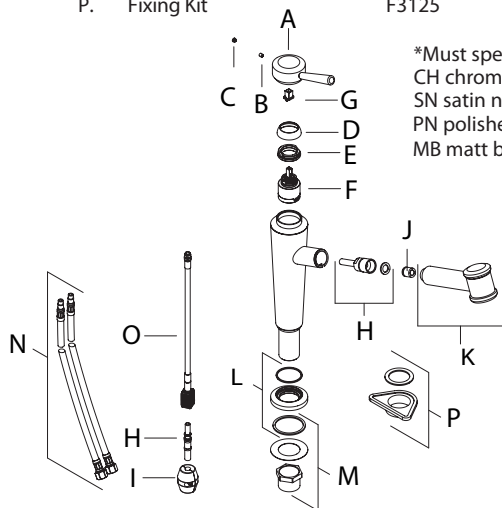

## LIMITED LIFETIME WARRANTY

Franke Kitchen Systems,LLC extends the following warranty to the original purchaser of its faucets effective January 1, 2003.

All faucets installed in a private residence will carry a limited lifetime warranty on all mechanical parts to be free of manufacturing defects in material and workmanship under normal usage. All chrome finishes carry a limited lifetime warranty; all other finishes are warranted for five (5) years form the original date of purchase.

**Marine and Outdoor Installation:** Franke faucets are NOT warranted for Marine and Outdoor installations.

This warranty applies only to the original owner, providing the product has been installed in accordance with our installation instructions, used as recommended and in a normal residential application. In the event of a warranty claim, the owner will be required to provide proof of purchase - save sales receipt. This warranty covers all components which make the product operational. Franke, at its option, may repair or replace the product or components necessary to restore the product to good working condition. Franke reserves the right to inspect the installation prior to the actual replacement of the product or component part. This warranty does not cover misuse or abuse, accidental damages, scuffs or scratches, improper installation, abnormal usage, negligence or damage caused by improper maintenance or cleaning. Normal wear of parts is excluded from the warranty. Damage caused by impurities or acts beyond our control are not covered. Any product or part which has been repaired or altered in any manner outside of Franke's factory, unless previously authorized in writing by Franke, will void warranty. **Any replacement excludes transportation and any labor re-installation costs.** This warranty does not allow recovery of incidental or consequential damages such as loss of use, delay, property damage or other consequential damage, and Franke accepts no liability for such damages.

The Franke warranty is limited to the above conditions and to the warranty period specified herein and is exclusive. Franke DISCLAIMS all other warranties, expressed or implied, including IMPLIED WARRANTIES OF MERCHANTABILITY AND/OR FITNESS FOR A PARTICULAR PURPOSE. This warranty gives you specific legal rights that may vary from state to state.

### Further information

For any further information about our products, about the installation of them or about the guarantee, please contact our customer service department:

**Franke Kitchen Systems**  
800 Aviation Parkway  
Smyrna, TN 37167, USA  
Phone: 800-626-5771  
Email: [ks-customerservice.us@franke.com](mailto:ks-customerservice.us@franke.com)

# INSTALLATION MANUAL

## ABSINTHE PULL-OUT SPRAY

### FFPS5200 - FFPS5220 - FFPS5270 - FFPS5280

151R11117#C08960



REV.0.06/2017

MAKE IT WONDERFUL



## TECHNICAL DATA

Flow Rate	1.75 GPM at 60 PSI
Recommended Water Pressure	30-75 PSI
Max. Water Pressure	145 PSI
Recommended Hot Water Temp.	120°-140° F
Hole Size For Faucet	1 3/8"

 Certifies this faucet complies with ASME A112.18.1 / CSA B125.1 & NSF 61, NSF 372 and AB1953

### NOTE:

Contact us immediately if you see inconsistencies.

Phone: (1- 800-626-5771)

website: [www.franke.us/ks](http://www.franke.us/ks)

email: [ks-customerservice.us@franke.com](mailto:ks-customerservice.us@franke.com)

## CONTENTS IN BOX

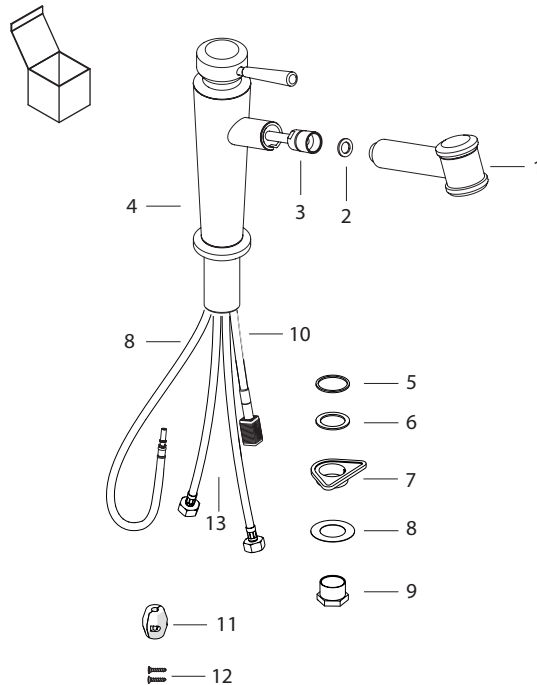

- |                           |                         |
|---------------------------|-------------------------|
| 1 Pull out spray assembly | 8 Fixing plate          |
| 2 Rubber washer           | 9 Fixing nut            |
| 3 Pull out hose           | 10 Pull out supply hose |
| 4 Faucet assembly         | 11 Weight               |
| 5 Rubber washer           | 12 Screws               |
| 6 Rubber washer           | 13 Supply hoses         |
| 7 Plastic flange          |                         |

## INSTALLATION INSTRUCTIONS

1. Remove all contents from the package and check for completeness.
2. Connect the pull out spray (1) to the pull out hose assy (3) hand tight. Ensure the rubber washer (2) is in place.
3. Turn off water supply.
4. Cut a mounting hole 1 3/8 diameter (35mm) in the desired position in counter top or sink (if one isn't available).
5. Slide the rubber washer (5) over the faucet shank and place in the escutcheon groove.
 

**ATTENTION:** The washer should be sitting between the countertop and faucet base.  
**DO NOT** use putty or other sealant at this location.

### NOTES:

**Solid surface installation:** The countertop mounting surface needs to be flat and free of debris otherwise the faucet may not sit properly. For tile installations, avoid installing faucet near or on top of grout lines. This may cause a weak joint between the faucet and the counter and could cause leaks.

6. Install the mounting hardware to the base of faucet body in the following order - rubber washer (6), plastic flange (7), fixing plate (8) as shown.

7. Tighten with the fixing nut (9) on the base of faucet body.

8. Connect the pull out hose (3) to the pull out supply hose (10) using the quick connect fitting. Slide the quick connect fitting sleeve to the "open" position, insert the hose fitting into the connector. You should hear a "click". Slide the sleeve to the "lock" position, you should hear another "click". This will ensure the fitting is sealed and locked.

9. Place the weight (11) on the pull out hose (3) with the screws (12) approximately 2" (50mm) above the bend in the bottom of the pull out hose.

10. Connect the flexible supply hoses (13) to the water supply in the house.

11. Remove the aerator using 11/16" (17 mm) wrench, turn on water, flush the faucet for any debris and check for leaks. Reinstall the aerator and ensure everything is functioning properly.

