

# INSTALLATION MANUAL

## CT-200



MAKE IT WONDERFUL



## CT-200

### Under Sink Chiller Unit Installation Instructions and Use and Care Guide

#### CHILLER SAFETY

Your safety and the safety of others are very important.

We have provided many important safety messages in this manual and on your appliance. Always read and obey all safety messages.



This is the safety alert symbol.

This symbol alerts you to potential hazards that can kill or hurt you and others.

All safety messages will follow the safety alert symbol and either the word “DANGER” or “WARNING”. These words mean:

**⚠ DANGER** You can be killed or seriously injured if you don't immediately follow instructions.

**⚠ WARNING** You can be killed or seriously injured if you don't follow instructions.

All safety messages will tell you what the potential hazard is, tell you how to reduce the chance of injury, and tell you what can happen if the instructions are not followed. You can be killed or seriously injured if you don't follow instructions.

**⚠ Warning:** The power cord on this product can expose you to chemicals including phthalates, such as diisononyl phthalate (DINP) or di(2-ethylhexyl)phthalate (DEHP), which are known to the State of California to cause cancer, birth defects or other reproductive harm. For more information go to [www.p65warnings.ca.gov](http://www.p65warnings.ca.gov).

#### ASSISTANCE OR SERVICE

If you need assistance or service, first see “Troubleshooting” section. Additional help is available by calling 1-800-626-5771 or write:

Franke Kitchen Systems  
Luxury Products Group  
800 Aviation Parkway  
Smyrna, TN 37167

Please include a daytime phone number in your correspondence. For installation and service, call: 1-800-626-5771 or visit our website at [www.frankeksd.com](http://www.frankeksd.com).

Keep this book and your sales slip together for future reference. You must provide proof of purchase or installation date for in-warranty service. Write down the following information about your appliance to help you obtain assistance or service if you need it. You will need to know your complete model number. You can find this information on the model and serial number label.

Dealer Name \_\_\_\_\_

Address \_\_\_\_\_

Phone Number \_\_\_\_\_ Model Number \_\_\_\_\_

Purchase Date \_\_\_\_\_

## CT-200

### Under Sink Chiller Unit Installation Instructions and Use and Care Guide

#### TECHNICAL DATA

Water temperature	50°F
Chiller capacity	1 gal/hr
Supply voltage	115 VAC
Frequency	60 Hz
Minimum water pressure	30 psi
Maximum water pressure	100 psi



This product is certified to ASME A112.19.3/CSA B45 for stainless steel plumbing fixtures, NSF/ANSI Standard 61, Annex G for lead content, which is in compliance with California's Health and Safety Code Section 116875 (commonly known as AB1953), and UL399 for drinking water coolers.

#### CONTENTS IN BOX

Call immediately if you see inconsistencies (1-800-626-5771) or visit [www.frankeksd.com](http://www.frankeksd.com)

1. Chiller unit
2. 4' of 1/4" blue poly tubing
3. (2) elbow push fittings
4. 6' of 1/4" white poly tubing
5. Wall mounting clip
6. #7 phillips screw
7. (2) 3/8" x 1/4" reducer fittings
8. 1/4" compression ferrule
9. 1/4" compression insert
10. 1/4" compression nut

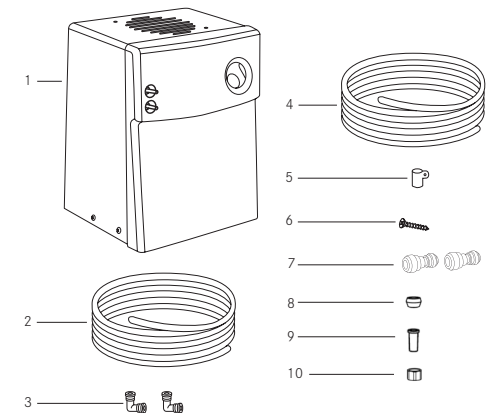

#### INSTALLATION REQUIREMENTS

**IMPORTANT:** For best results, Franke recommends its products to be installed by a licensed, professional plumber. The installer should familiarize themselves with how this chiller will be installed. Make certain to observe all local plumbing and building codes during installation of this unit. Inspect location where the chiller will be installed. Proper installation is the responsibility of the installer. Make sure you have everything necessary for the correct installation. Water connections use push fittings that DO NOT require any types of sealing compounds to prevent leakage. Use of any sealing compounds will VOID THE PRODUCT WARRANTY.

This chiller is not a water purifier. For water purification, Franke separately offers and strongly recommends using the chiller with our line of professional under counter filtration products to enhance water quality, and improve performance and durability of the chiller. These instructions are written assuming the use of the Franke filtration products.

This chiller must be used in conjunction with a drinking water dispensing faucet, also sold separately. Franke recommends pairing this chiller with one of our Little Butler® point of use dispensing faucets, as outlined in these instructions.

## CT-200

### Under Sink Chiller Unit Installation Instructions and Use and Care Guide

#### LOCATION REQUIREMENTS

Determine where the chiller and all components being used in the installation should be mounted beforehand and make sure there is adequate clearance for plumbing and electrical components and there is enough tubing to reach the intended mounting positions. For best performance, position the chiller to allow a 2" (5 cm) space around the top and sides. Do not put any objects on top of the chiller that could obstruct the fan.

**⚠ WARNING**



**ELECTRICAL SHOCK HAZARD**  
Plug into a grounded 3 prong outlet.  
Do not remove ground prong.  
Do not use an adapter.  
Failure to follow these instructions can result in death, fire, or electrical shock.

#### ELECTRICAL REQUIREMENTS

A 120-volt, 60-Hz, 15- or 20-amp, grounded electrical supply is required. It is recommended that a separate circuit serving only your chiller unit be provided. Use an outlet that cannot be turned on/off by a switch.

#### RECOMMENDED GROUND METHOD

The chiller must be grounded. This appliance is equipped with a power supply cord with a 3 prong ground plug. To minimize possible shock hazard, the cord must be plugged into a mating, 3 prong, ground-type outlet, grounded in accordance with all national and local codes and ordinances. If a mating outlet is not available, it is the personal responsibility and obligation of the customer to have a properly grounded, 3 prong outlet installed by a qualified electrician.

#### WATER SUPPLY REQUIREMENTS

A cold water supply with a minimum pressure of 30 psi and a maximum pressure of 100 psi must be available to the chiller. It can come directly from the water supply of the home, or from a water filtration system. A Franke filtration system is highly recommended.

#### INSTALLATION INSTRUCTIONS

**IMPORTANT:** For subsequent steps, it will be required to cut and route tubing to fit the specific application in your home. All tubing must be cut squarely and free of burrs. Ensure there is no damage within 1" of the cut end.

#### DO NOT USE ANY FORM OF SEALING COMPOUNDS, this is not required for push fit connections, and using sealing compounds could cause leaks. All tubing connections must be firmly seated. Tubing must be routed to avoid sharp bends and have enough slack to avoid straining connections. A P-clip and mounting screw is included to hold the tubing in place as needed. Pull gently on each connection to make sure they are secure. See Diagram 1 for details on tubing installation and removal.

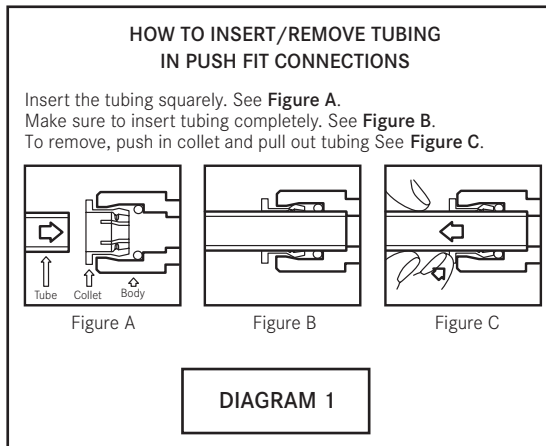

## CT-200

### Under Sink Chiller Unit Installation Instructions and Use and Care Guide

#### INSTALLATION INSTRUCTIONS

The following instructions pertain to the connection of this chiller to a Franke filtration system and Franke Little Butler® series dispensing faucets. The connection options for all compatible Franke products will be reviewed in this document. Make sure you understand which connection option applies to your specific installation.

Diagram 2 illustrates a general overview of the entire installation for ALL COLD ONLY Little Butler® dispensing faucets.

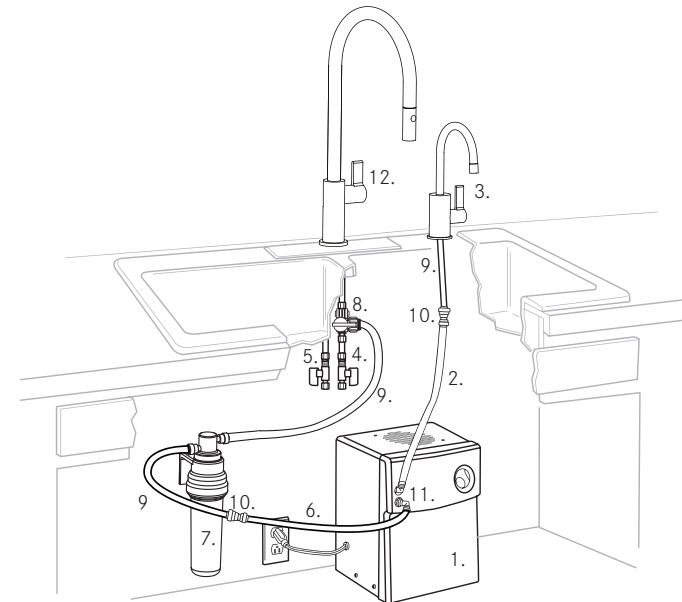

**DIAGRAM 2:  
COLD ONLY LITTLE BUTLER DISPENSING FAUCET**

- |   |   |
|---|---|
| <ol style="list-style-type: none"><li>1. Chiller unit</li><li>2. 1/4" blue tubing</li><li>3. Franke Little Butler® cold only faucet (sold separately)</li><li>4. Cold water supply from home</li><li>5. Hot water supply from home</li><li>6. 1/4" white tubing</li><li>7. Franke filtration system (sold separately)</li><li>8. 10306 shut-off valve (sold separately)</li></ol> | <ol style="list-style-type: none"><li>9. 3/8" tubing</li><li>10. 3/8"-1/4" reducer push fitting or 1/4" compression fitting (not shown)</li><li>11. 1/4" elbow push fitting</li><li>12. Franke kitchen faucet (sold separately)</li></ol> |
|---|---|

## CT-200

### Under Sink Chiller Unit Installation Instructions and Use and Care Guide

#### INSTALLATION INSTRUCTIONS

1. After chiller is unpacked, place upright for 24 hours before plugging it in.
2. Ensure the water supply is turned off.
3. Install a suitable drinking water dispensing faucet (sold separately) per the instructions. The following steps outline how the chiller is to be connected to a Franke COLD ONLY Little Butler® dispensing faucet. Any other faucet may require additional steps or hardware to install.

4. Connect the 3/8" black tubing (9) from the exit of the Franke filtration system (7) to the 3/8" to 1/4" reducer push fitting (10). Cut a piece of the white 1/4" poly tubing (6) long enough to connect the reducer push fitting (10) to the elbow push fitting (11) on the chiller. Connect the tubing (6) from the reducer push fitting (10) to one of the elbow push fittings (11), and connect the other end of the elbow push fitting to the "water in" connection on the chiller.

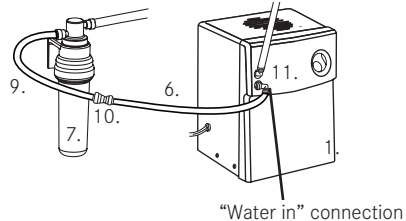

5. Next connect the other elbow push fitting (11) to the "water out" connection on the chiller. Cut a piece of the blue 1/4" poly tubing (2) long enough to connect to the elbow push fitting (11) to the inlet of the drinking water faucet and connect the tubing to the elbow fitting (11).

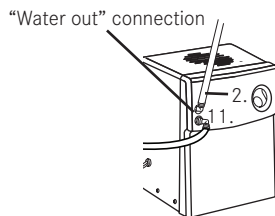

## CT-200

### Under Sink Chiller Unit Installation Instructions and Use and Care Guide

6. Connect the 1/4" tubing (2) from the elbow fitting (11) connected to the "water out" connection on the chiller (1) to the faucet (3). This step will vary, based on dispensing faucet being connected. Identify the faucet you are connecting and follow the appropriate instruction:

#### Option 1:

For dispensing faucets with 3/8" push fitting connections like DW50XX, DW61XX, DW80XX, and DW90XX models:

Connect the 1/4" tubing (2) from the chiller to a 3/8" to 1/4" reducer push fitting (10) and use the black 3/8" tubing supplied with the dispensing faucet (9) to connect the dispensing faucet (3) to the 3/8" side of the reducer push fitting (10).

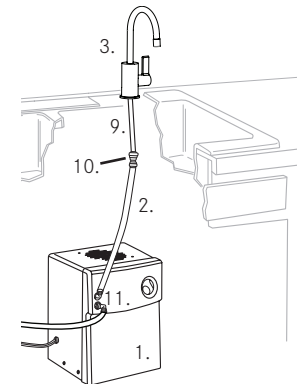

#### Option 2:

For dispensing faucet models with 1/4" compression fitting connections like DW100XX, DW110XX, and DW120XX models:

Slide the compression nut (20) and plastic ferrule (19) onto the 1/4" tubing (2) from the chiller (1). Slide the plastic insert (18) into the end of the 1/4" tubing from the chiller. Insert the tubing with compression fitting hardware attached into the mounting nipple (17) of the faucet (3) and tighten the compression nut (20).

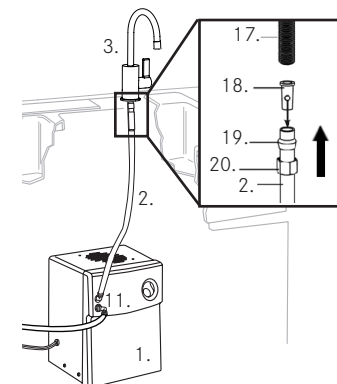

#### Option 3:

For dispensing faucet models with 1/4" push fitting connections like DW13050 and DW14050 models:

Connect the 1/4" tubing (2) from the chiller (1) directly to the cold water inlet of the dispensing faucet (3).

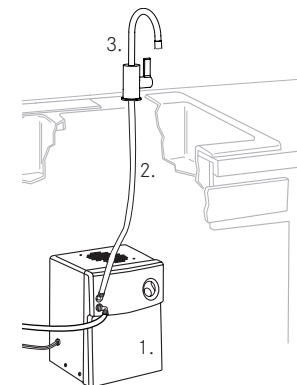

## CT-200

### Under Sink Chiller Unit Installation Instructions and Use and Care Guide

7. Connect a piece of 3/8" tubing (9) from the inlet of the filtration system (7) to the cold water supply of the home (4). Franke recommends using a 10306 shut-off valve (8) that allows for connection directly to the kitchen faucet as illustrated.

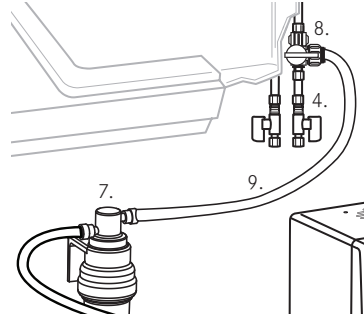

8. If you are NOT installing a filtration system with the chiller, you will connect the cold water supply from the home (4) or the 10306 shut-off valve (8) if utilized, directly to the 3/8" to 1/4" reducer (10) using the 3/8" poly tubing (9), and then connect the 3/8" x 1/4" reducer (10) to the chiller inlet elbow (11) using the 1/4" poly tubing (2).

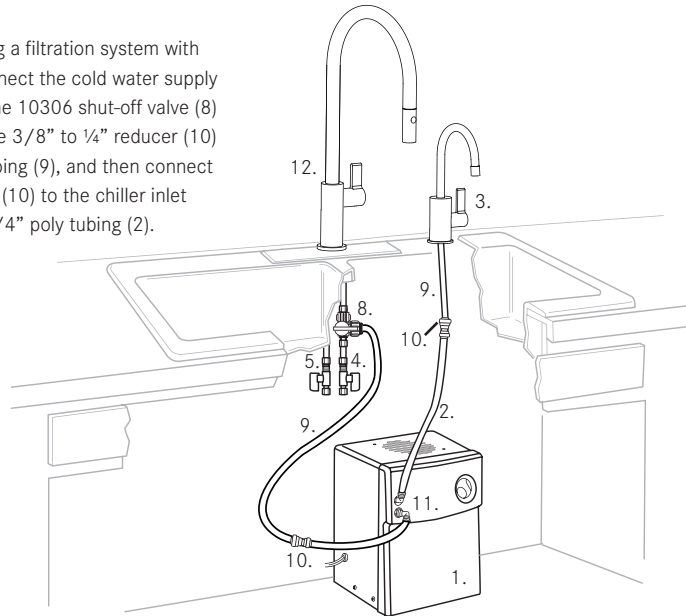

**DIAGRAM 3:**  
Connection overview with no filtration system

## CT-200

### Under Sink Chiller Unit Installation Instructions and Use and Care Guide

9. Slowly turn on water supply. Open the cold water valve and allow the dispensing faucet to run for at least 1 minute. Check all connections for leaks.
10. Plug in the chiller to a suitable power supply (see electrical requirements section). Prior to drinking water, flush water through chiller for at least 5 minutes.

#### USAGE

##### SETTING THE TEMPERATURE

- Your chiller has a dial for water temperature control.
- For colder water: Turn it clockwise (to the right).
- For less cold water: Turn it counterclockwise (to the left).
- To shut down the chiller: Turn the dial to the Off position at full counterclockwise (extreme left).
- Allow one hour to obtain chilled water.

#### MAINTENANCE

##### DISCONNECTING AND STORAGE

1. Unplug the chiller.
2. Shut off water supply to chiller.
3. Open faucet to release pressure.
4. Disconnect the water lines attached to the chiller by depressing collet on push fittings.
5. Tip chiller to the left side (power cord side) and drain water into a large container.
6. Set chiller in its normal upright position for storage.

##### RECONNECTING THE CHILLER

1. Shut off water supply to chiller.
2. Put chiller back in position, allowing a 2" (5 cm) space around the side and top.
3. Connect chiller as described in the "Installation Instructions" section.
4. Slowly open main water supply valve and open faucet until water flows.
5. Plug in chiller and set dial to desired water temperature (See the "Setting the Temperature" section).

## CT-200

### Under Sink Chiller Unit Installation Instructions and Use and Care Guide

#### Spare / Replacement Part List

1. 10304
2. 10327
3. 10322
4. 10324
5. 10325
6. 10326

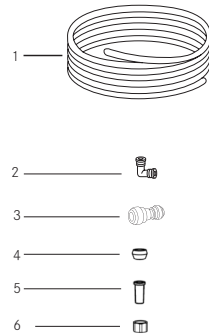

#### TROUBLESHOOTING

Problem	Check the Following
Water is not cold.	<ul style="list-style-type: none"><li>- Check that the circuit breaker has not tripped or the house fuse has not blown.</li><li>- Check that power supply cord is plugged into electrical outlet.</li><li>- Check if the electrical outlet is operated by a switch. The switch may have turned the power off.</li><li>- Cold water in tank is still being chilled. Wait 15 minutes and check temperature again.</li><li>- Check that the Temperature Control is set to the "Max" setting.</li></ul>
Cold water drips or sputters from spout.	<ul style="list-style-type: none"><li>- Check that tubing is not bent or kinked.</li></ul>
Water does not flow from spout.	<ul style="list-style-type: none"><li>- Make sure main supply valve is open.</li><li>- Check that water pressure to the chiller is 30 psi (138 kPa) minimum.</li><li>- Check to see if chiller is attached to hot water line. If so, attach to cold water line.</li><li>- Check filters for proper installation.</li></ul>
Unpleasant taste.	<ul style="list-style-type: none"><li>- If the dispenser has not been used for 3 or more days or if only 1 to 3 cups of water are dispensed in a day, the tank may need to be purged. Open the faucet for 2 to 3 minutes to purge the old water from the tank. Allow new water in tank to reach desired temperature (approximately 1 hour) before dispensing water.</li><li>- Check to see if filtration element in filtration system needs to be replaced</li></ul>

## CT-200

### Under Sink Chiller Unit Installation Instructions and Use and Care Guide

#### WARRANTY

Congratulations on the purchase of this Franke product! Franke is one of the world's largest manufacturers of kitchen systems. Our products are manufactured using the highest degree of technology, quality and design. As a result, we are proud to offer the following warranty:

Warrantor: Franke Kitchen Systems Luxury Products Group, 800 Aviation Parkway, Smyrna, TN 37167

#### ONE-YEAR LIMITED WARRANTY

The Warrantor promises the original purchaser to repair or replace, at the Warrantor's option, any part of this CT-200 Chiller unit that proves to be inoperative due to a defect in material or workmanship under normal use, for a period of one (1) year from the date of purchase. This warranty will be honored provided the CT-200 Chiller unit has been installed and operated in accordance with the written instructions furnished with the CT-200 Chiller unit.

#### GENERAL PROVISIONS AND EXCLUSIONS

This warranty applies only within Canada and the United States of America. This warranty will be honored if the unit is returned in the original carton (or suitable replacement) along with proof of purchase. This warranty does not apply to bonus and/or accessory items sold with the CT-200 Chiller unit. This warranty does not apply if the affixed serial number is removed, defaced or obliterated. This warranty does not cover poor performance, failure or damage of any part resulting from external causes such as alterations, abuse, misuse, misapplication, corrosion, limiting conditions or acts of God. This warranty and the Underwriter's Laboratory or Canadian Standard Association listing for this CT-200 Chiller unit are automatically voided if this CT-200 Chiller unit is altered, modified or combined with any other machine or device. Alteration or modification of this CT-200 Chiller unit may cause serious flooding, and/or hazardous electrical shock or fire.

**Except as set forth herein or required by law, the Warrantor makes no other warranty, guarantee or agreement, express, implied or statutory, including any IMPLIED WARRANTY OF MERCHANTABILITY OR FITNESS FOR A PARTICULAR PURPOSE. The Warrantor does not assume or authorize any person to assume any obligations of liability in connection with this product. In no event will the Warrantor be liable for indirect, special or consequential damages (including, without limitation, economic loss) or for any delay in the performance of this agreement due to causes beyond its control. Some states or provinces do not allow limitations on how long an implied warranty lasts, so the above limitation may not apply to you. Some states or provinces do not allow the exclusion or limitation of incidental or consequential damages, so the above limitation or exclusion may not apply to you. This warranty gives you specific legal rights, and you may also have other rights which vary from state to state or from province to province.**

If you need service, first see Troubleshooting Solutions. Additional help can be found by calling our customer service line at 1-800-626-5771 or by writing: CT-200 filtration system, Franke Kitchen Systems Luxury Products Group, 800 Aviation Parkway, Smyrna, TN 37167.

Franke Kitchen Systems  
Luxury Products Group  
800 Aviation Parkway  
Smyrna, TN 37167  
800-626-5771  
[www.frankeksd.com](http://www.frankeksd.com)

Part No. INST-CT-200  
Print 01/2018

© 2018 Franke Consumer Products, Inc.  
All rights reserved. Printed in USA.

MAKE IT WONDERFUL

