

# 3D CARRIER BASKET TRANSPORTER



Item #:
Project:
Quantity:

## PRODUCT OVERVIEW

3D Carrier Basket Transporter systems carry prepared food products from the kitchen loading zone to a remote service/ front counter zone, which is not in-line with loading point, either on the same floor or on a different level. Carriers are continuously loaded and unloaded to ensure consistent delivery of fresh product to customers. System route can be in 3-dimensional directions with fully customizable track options.

## STANDARD PRODUCT FEATURES

- Aluminum, stainless steel, and plastic design ensures easy cleaning and maintenance
- Customized design to best suit the unique project requirement - enable a challenging site layout or build an extended selling point.
- Efficient and hygienic delivery system moves multiple products between building floors within seconds
- Modular track design ensure flexibility to meet any site conditions and ease of installation
- Lightweight design and low-power motor reduces power consumption
- Built-in safety features and emergency shut-off system ensure safe operation of system at all times
- Includes spare parts box with critical parts for peace of mind

FOR COMMERCIAL USE ONLY

Franke Foodservice Systems Inc  
800 Aviation Parkway  
Smyrna, TN 37167  
Tel +1-877-379-3769  
franke.com

*Make  
it  
Wonderful*



# 3D CARRIER BASKET TRANSPORTER

ISOMETRIC VIEW

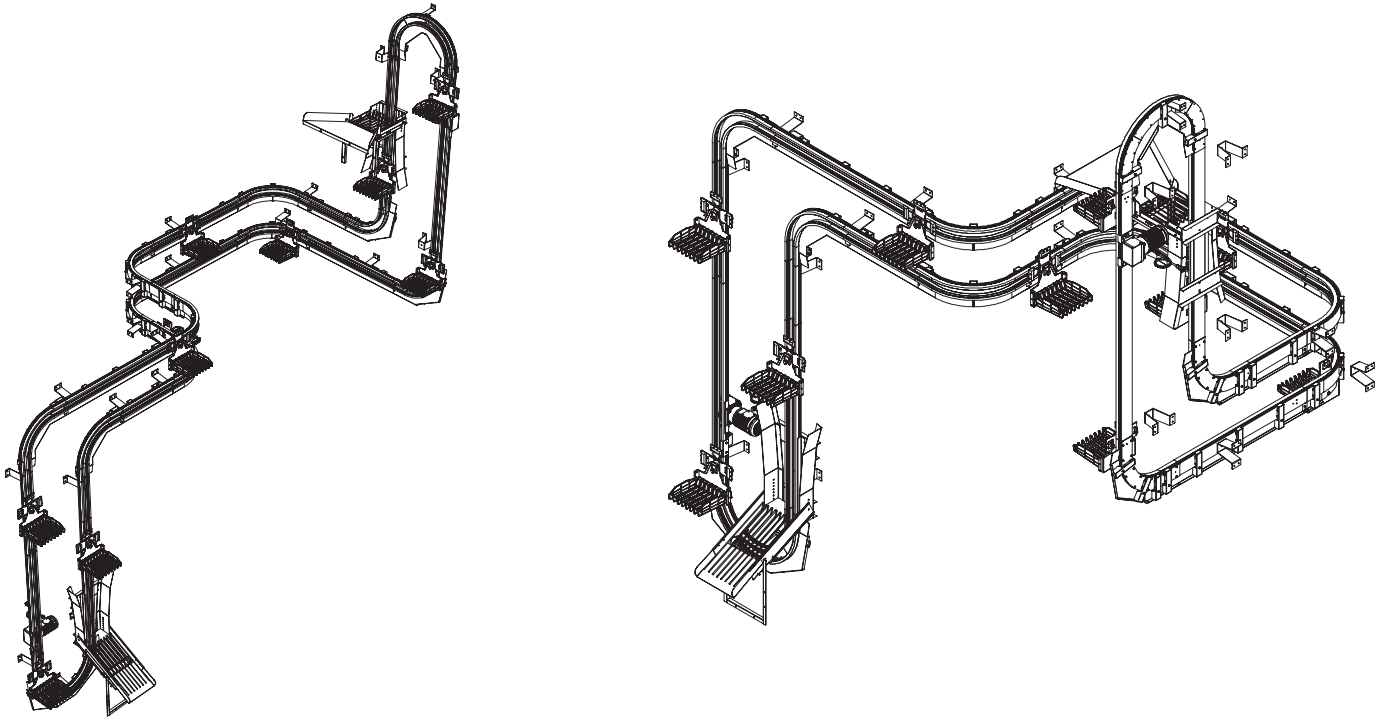

## DIMENSIONS

Track Length	32.8' - 164.0'	10.0 m - 50.0 m
Number of Carriers	4 (Minimum) - 36 (Maximum)	
Max. Payload per Carrier	4.4 lbs	2.0 kg
System Deadweight	260 lbs - 520 lbs	120 kg - 240 kg

## ELECTRICAL

Voltage/Frequency/Phase	115-230V/50-60Hz/1Ph	
Power	½ HP	0.5 kW
Motor	AC Gearhead Drive Motor	
Motor Power Load	2.0 A	
System Speed	1.6 ft/s	0.5 m/s

 RECYCLE DOCUMENTS AND EQUIPMENT RESPONSIBLY

© 2020 Franke Foodservice Systems, Inc. This media is the confidential and proprietary property of Franke Foodservice Systems, Inc. and shall not be reproduced in any form of media without the express written permission of a Franke representative. Due to continuous product development, Franke reserves the right to make changes in design and specifications without prior notice. Under license Franke Technology and Trademark Ltd., Switzerland. Printed in USA. Document Part # 19015613, Rev. A, June 15, 2020

*Make it Wonderful*

