

CARRIER BASKET TRANSPORTER - VERTICAL

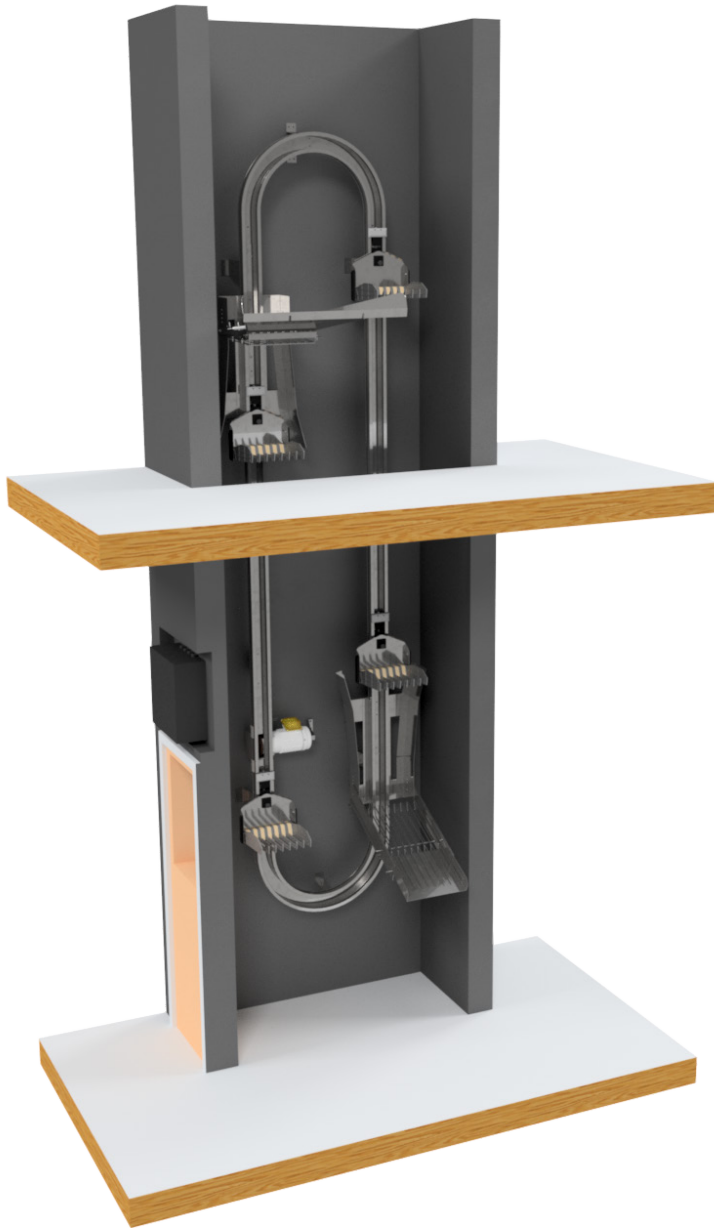

Top-to-Bottom configuration shown



Franke Foodservice Systems Inc
800 Aviation Parkway
Smyrna, TN 37167
Tel +1-877-379-3769
franke.com

Item #:
Project:
Quantity:

PRODUCT OVERVIEW

Carrier Basket Transporter - Vertical system carries prepared food products from the kitchen loading zone to the customer service/front counter zone. Carriers are continuously loaded and unloaded to ensure consistent delivery of fresh product to customers. System available in top-to-bottom and bottom-to-top directions with fully customizable track options.

STANDARD PRODUCT FEATURES

- Aluminum, stainless steel, and plastic design ensures easy cleaning and maintenance
- Agile layout design with significantly smaller building footprint optimizes real estate investment
- Efficient and hygienic delivery system moves multiple products between building floors within seconds
- Modular track design ensure flexibility to meet any site conditions and ease of installation
- Lightweight design and low-power motor reduces power consumption
- Built-in safety features and emergency shut-off system ensure safe operation of system at all times
- Includes spare parts box with critical parts for peace of mind

CARRIER BASKET TRANSPORTER - VERTICAL

Approval _____

Make it wonderful



CARRIER BASKET TRANSPORTER - VERTICAL

FRONT VIEW

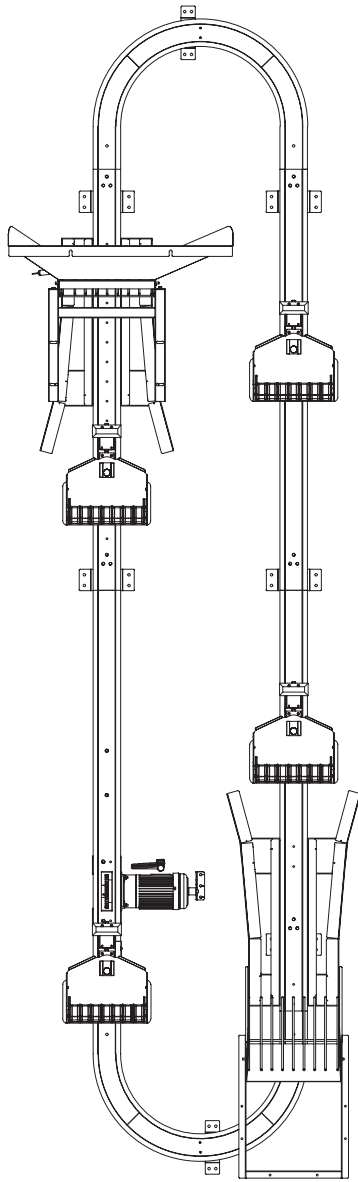

SIDE VIEW

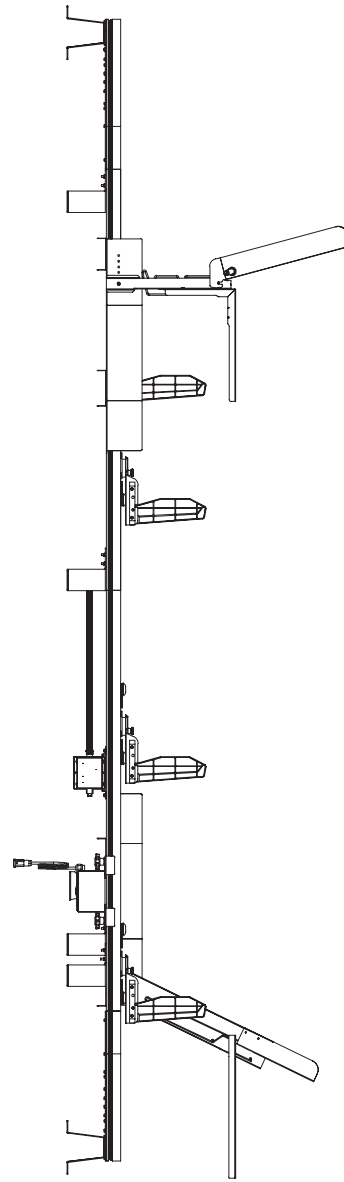

DIMENSIONS

Slab-to-Slab Height	2.5 m - 10 m	8.2' - 32.8'
Track Length	8.7 m - 25.7 m	28.5' - 84.3'
Number of Carriers	4 (minimum)	20 (maximum)
Max. Payload per Carrier	2 kg	4.4 lbs
Avg. System Dead-weight	120 kg	260 lbs

ELECTRICAL

Voltage/Frequency/Phase	115-230V/50-60Hz/1Ph	
Power	0.2 kW	¼ HP
Motor	230V AC gearhead drive motor	
Motor Load	0.60 Amp	
System Speed	0.5 m/sec - 0.8 m/sec	

 **RECYCLE DOCUMENTS AND EQUIPMENT RESPONSIBLY**

© 2019 Franke Foodservice Systems, Inc. This media is the confidential and proprietary property of Franke Foodservice Systems, Inc. and shall not be reproduced in any form of media without the express written permission of a Franke representative. Due to continuous product development, Franke reserves the right to make changes in design and specifications without prior notice. Under license Franke Technology and Trademark Ltd., Switzerland. Printed in USA. Document Part # 19013505, Rev. A, May 1, 2019

Make it Wonderful

